

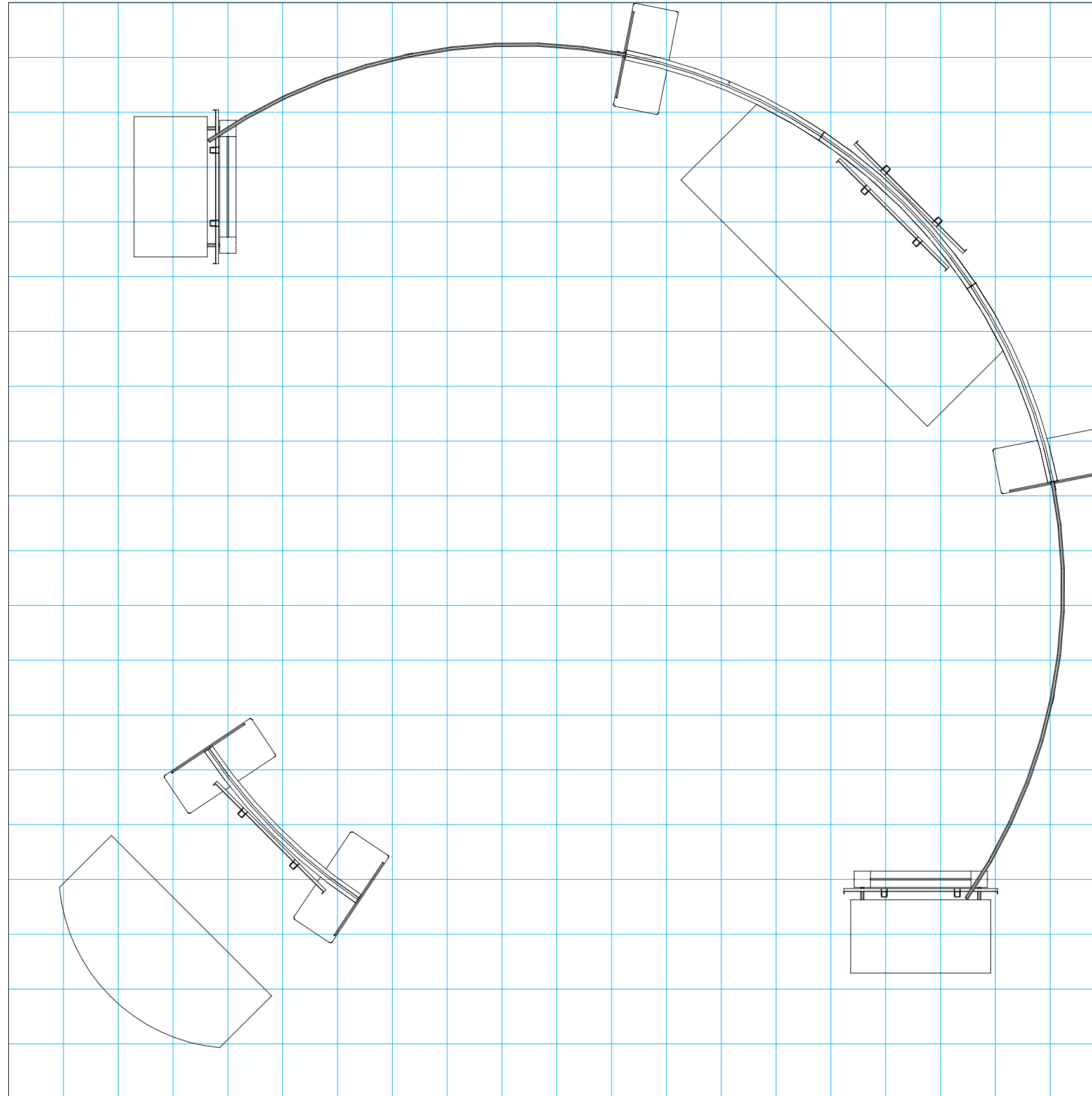

# SETUP INSTRUCTIONS



 = 1 sq foot

## General Setup Instructions

- Read entire setup instruction manual prior to unpacking parts and pieces.
- The setup instructions are created specifically for this configuration.
- Setup instructions are laid out sequentially in steps, including exploded views with detailed explanation for assembly.

## Cleaning & Packing

- For Cleaning Metal, Plex, & Laminate Parts: Use a **MILD NON-ABRASIVE** cleanser and soft cloth/paper towel to clean all surfaces.
- Keep exhibit components away from heat and prolonged sun exposure. **Heat and UV exposure will warp and fade components.**
- Retain all provided Packing Materials. All provided packing materials are for ease of repacking & component protection.

## Disassembly

- For loss prevention, tighten all set screws and locks during disassembly.

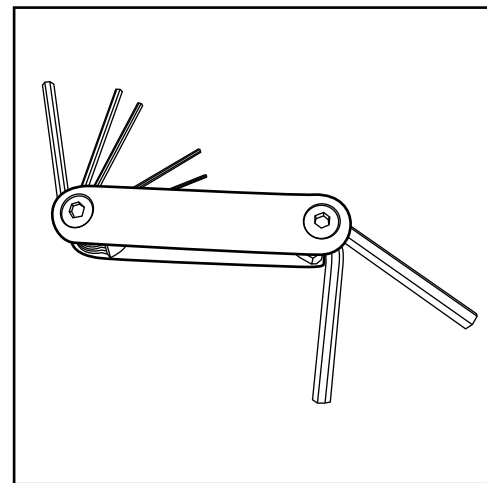

Hex Tool - Essential for Assembly

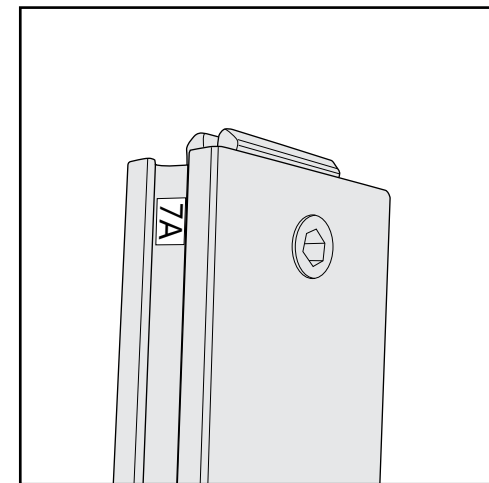

Part Identification - Numbering

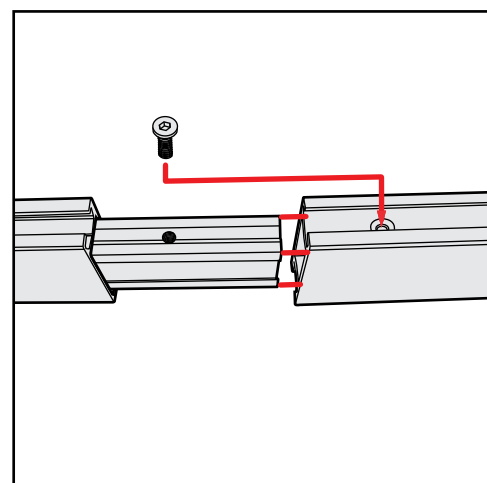

Spline Connection

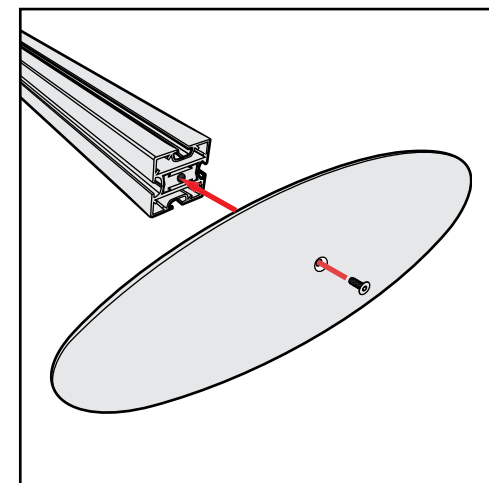

Base Plate & Extrusion Connection

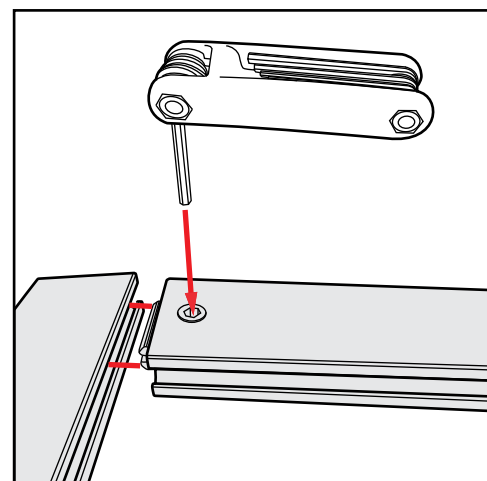

Extrusion & Lock Connection

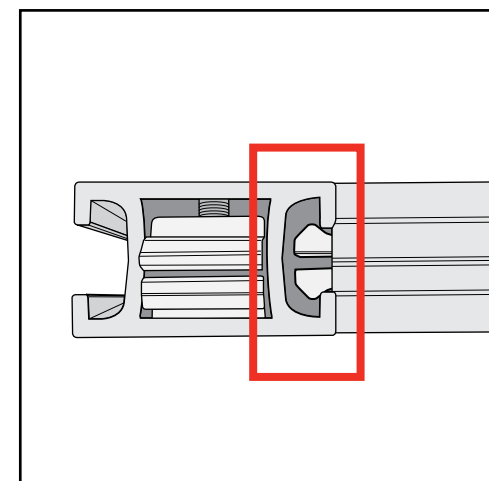

Engaged Lock



# WARNING

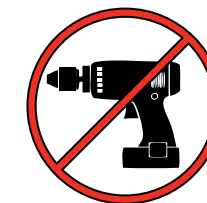

DO NOT USE POWER TOOLS

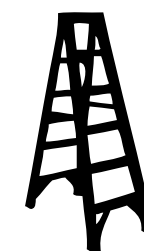

LADDERS OR LIFTS  
MAY BE REQUIRED



ALL CONNECTIONS MUST  
BE TIGHTLY SECURED

## Side-by-Side Assembly

- 1) Frames: Place frames side-by-side with one higher than the other, then slide panel down to lock panels securely together.
- 2) Corner Connectors: Repeat Step 1 for installing corner connectors to frames.

## Side-by-Side Disassembly

- 1) Pull pin lock outwards to disengage.
- 2) Pull frames upward and apart at the same time to detach.

Assembly

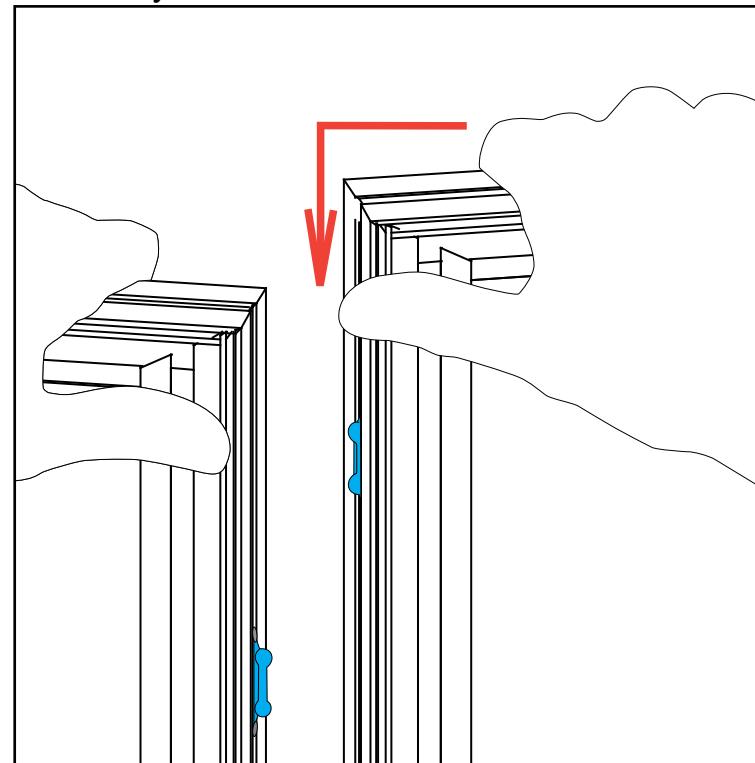

Assembly Cont'd

Push pin lock into hole of connecting frame.  
Note: Block of pin lock will secure in groove.

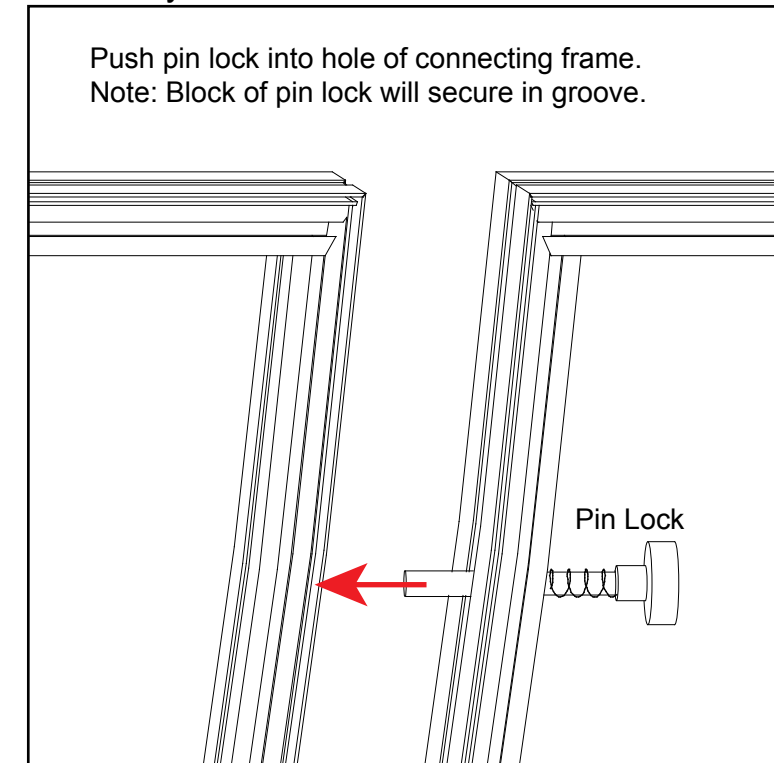

Corner Connector

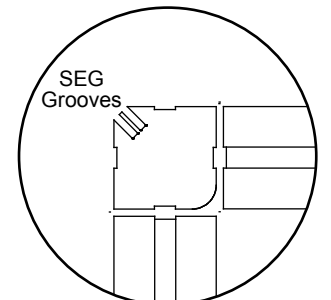

Top View

Note: Orientation of Corner Connector may change.

## Stacking Assembly

- 1) Place one horizontal frame on top of the other, lining up the center grooves.
- 2) Turn stacking lock clockwise to tighten into place. Repeat for each lock.

## Stacking Disassembly

- 1) Turn the stacking lock counter-clockwise to loosen.
- 2) The whole spring on the stacking lock should be in view to release each frame. The disengaged spring should release the stacking lock. If not, keep turning the stacking lock until it disengages.

Stacking

Push stacking lock into the slot of the upper frame, then spin the cap to tighten the lock.

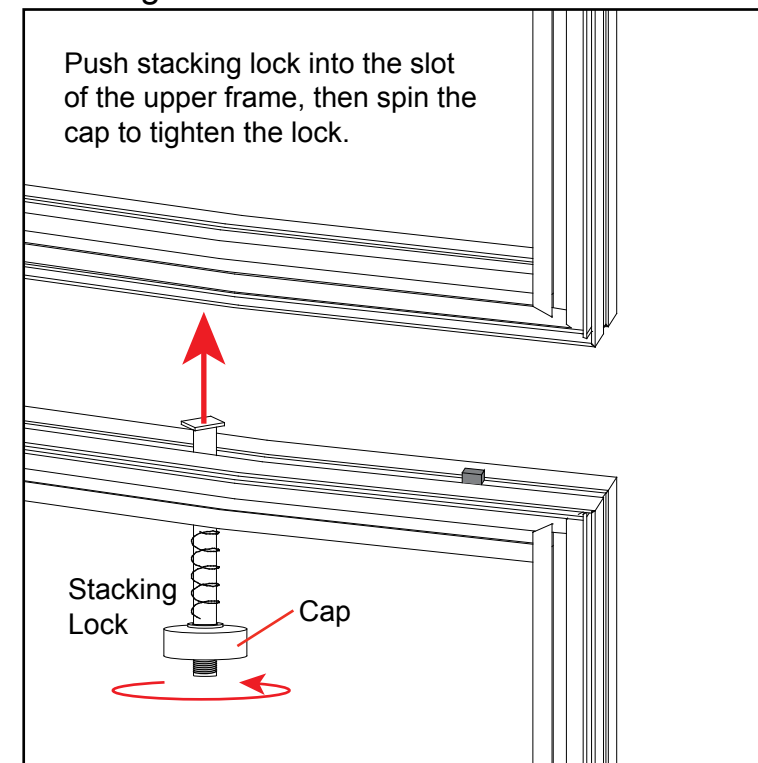

Unstacking

Disengage the stacking lock by spinning the cap counter clockwise and pulling down.

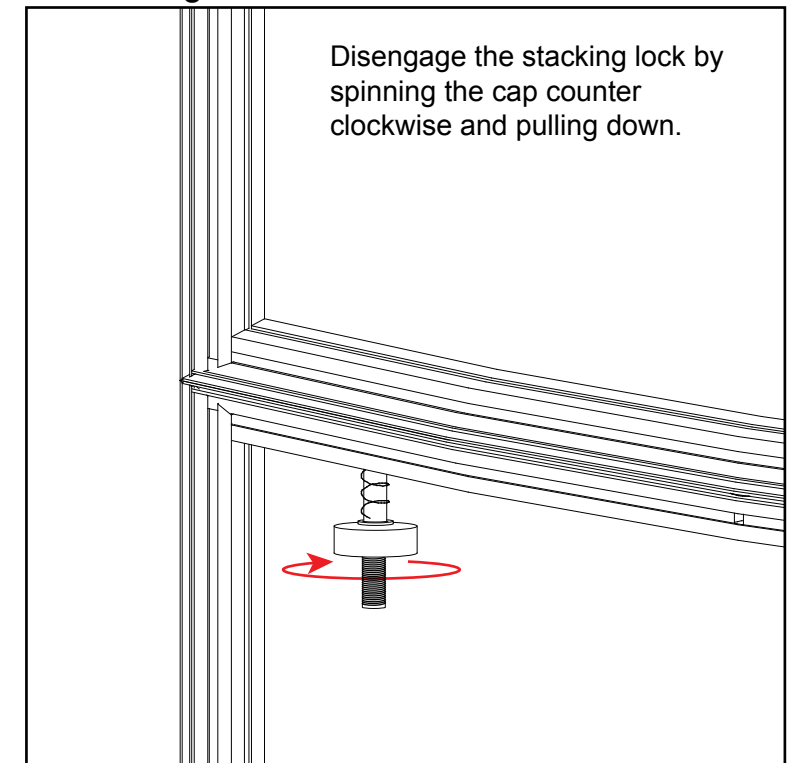

# SEG Graphic Installation *in 3 Steps*

*The Perfect Fit*

## STEP 1: Attach Corners

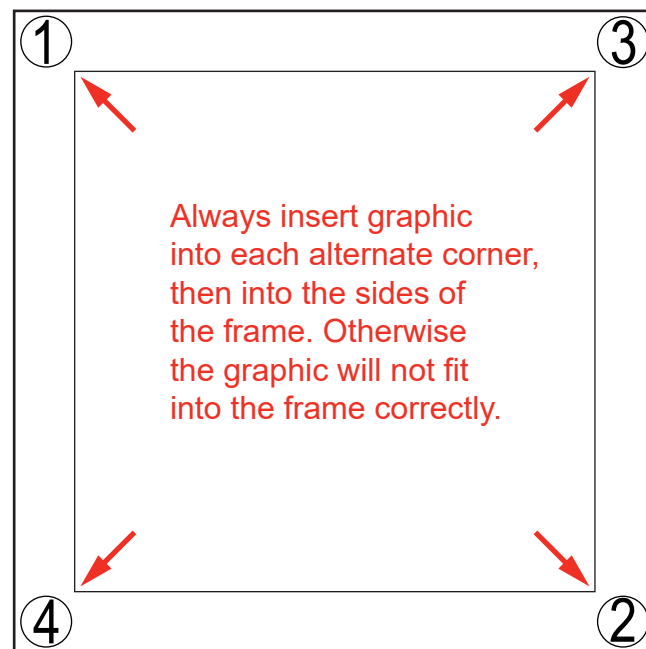

## STEP 2: Attach Middle

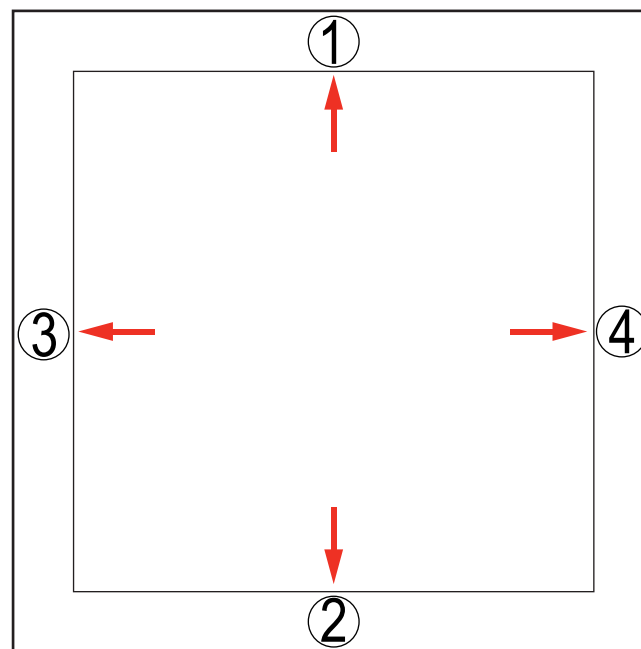

## STEP 3: Attach Sides

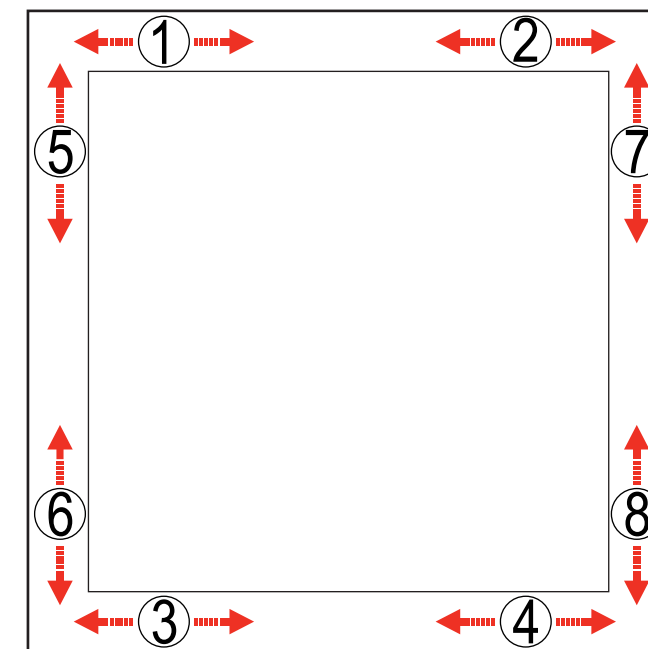

Insert narrow side of silicone welt into the channel at corner 1, with fabric to the outside.

Repeat for opposite corner 2, then corner 3, then corner 4.

Once corners are attached, press the middle of edge 1 into the channel. Then press middle of edge 2 into the channel on opposite side.

Repeat with edge 3 & 4.

Once the middle of sides are attached, fully press the silicone welt into the channel, between center and corner at location 1. Repeat the process between center and corner at location 2.

Do the same for welt on opposite side, at locations 3 & 4. Then repeat for locations 5 & 6 and 7 & 8.

Once the welt is fully inserted on all sides, smooth out edges as needed for a perfect fit.



To remove the graphic from the frame, locate the fabric **pull tab**. Gently pull on the tab to remove the graphic.

Install video:



CRATE PACKING

Keep internal extrusions attached to Gravitee panels.  
DO NOT REMOVE.

Item	Qty.	Description
1	1	47.123"w x 95"h lower Curved Gravitee panel
2	1	47.123"w x 95"h lower Curved Gravitee panel w/ S44
3	1	47.123"w x 95"h lower Curved Gravitee panel
1	1	47.123"w x 95"h upper Curved Gravitee panel
2	1	47.123"w x 95"h upper Curved Gravitee panel
3	1	47.123"w x 95"h upper Curved Gravitee panel
1	2	Corner Base Plate
--	4	Clear Break Infills

Steps:

Refer to the Gravitee Assembly general information page.

- 1) Attach Base Plates [1] to lower panels [1] & [3]. See [Base Plate Attachment](#) detail.
- 2) Assemble Gravitee panels [1-2-3] & [1-2-3] together as shown.
- 3) Attach Clear Break Infill to back side of Gravitee wall at joints between panels. See [Clear Break Infill Attachment](#).

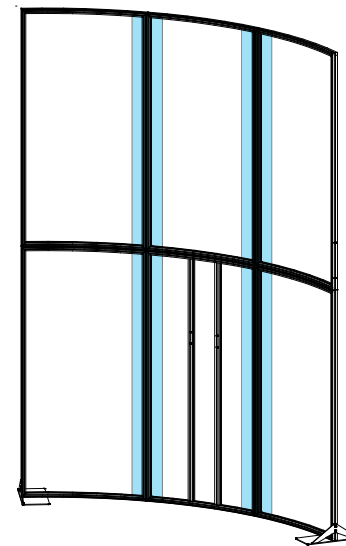
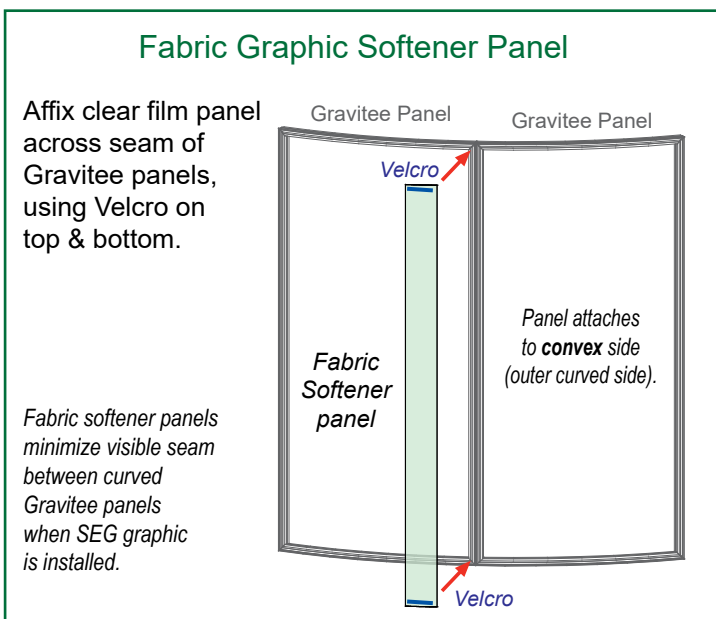
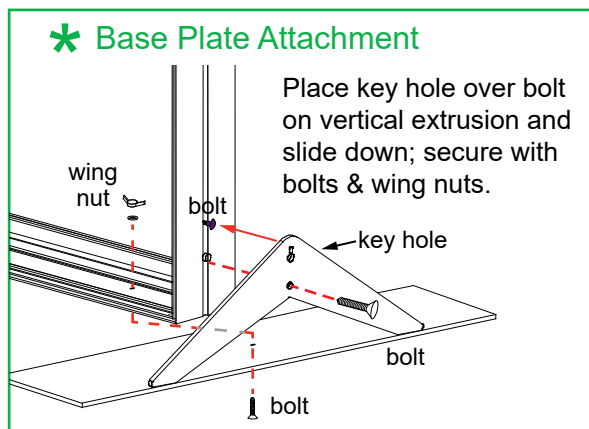

When assembled

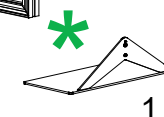
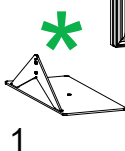
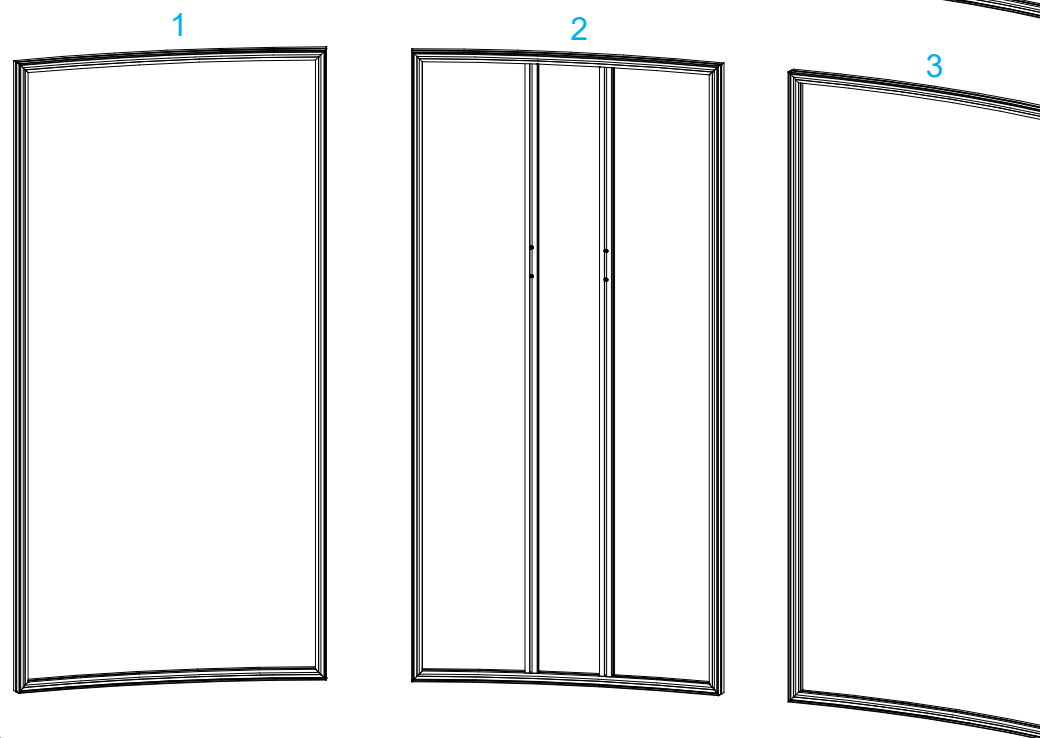
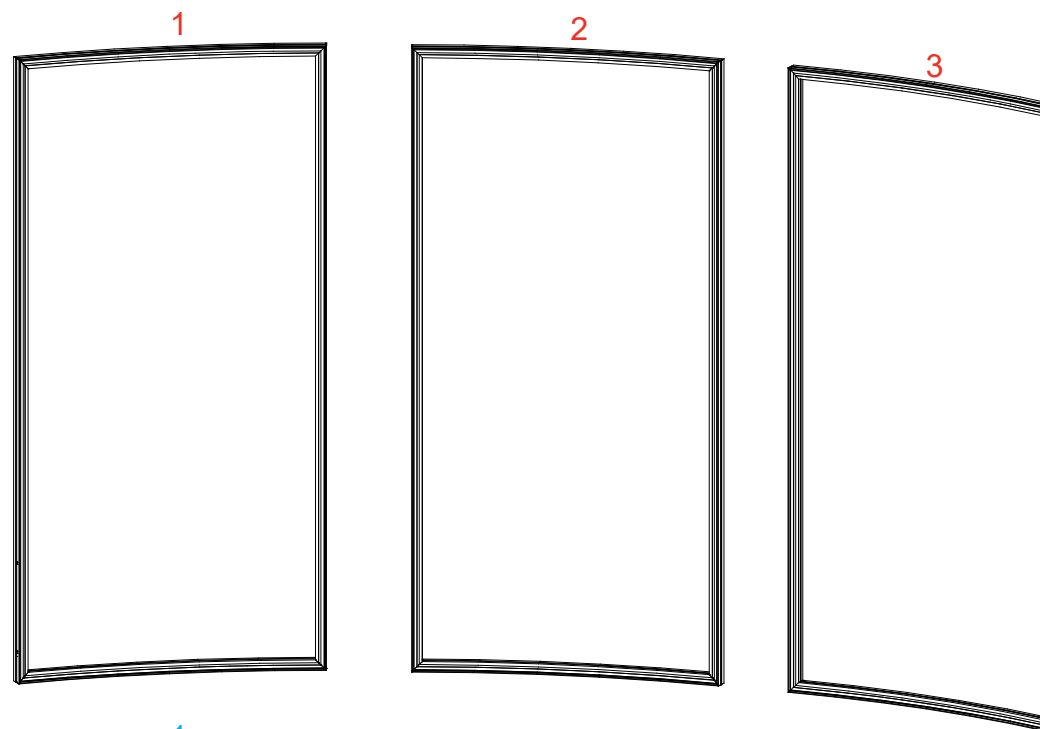

FRONT VIEW

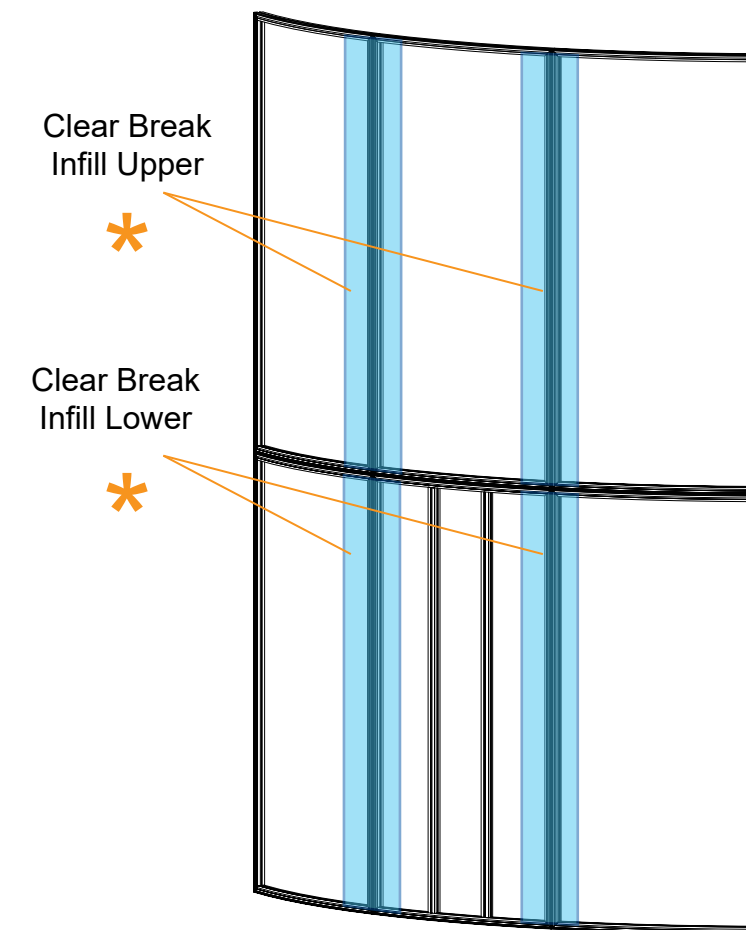

BACK VIEW

Item	Qty.	Description
--	2	Large Monitor Mount
--	4	1" Standoff Barrel
--	4	2" Standoff Barrel

Steps:

Refer to the *SEG Installation general information page*.

- 1) Apply SEG graphics to backwall assembly, as shown.
- 2) Attach Monitor Mounts to front & back of lower panel [2].  
See [Monitor Mount Attachment](#) detail.

**\* Monitor Mount Attachment**

Slide V4 connectors into vertical channel of extrusions & tighten set screws to secure in place.

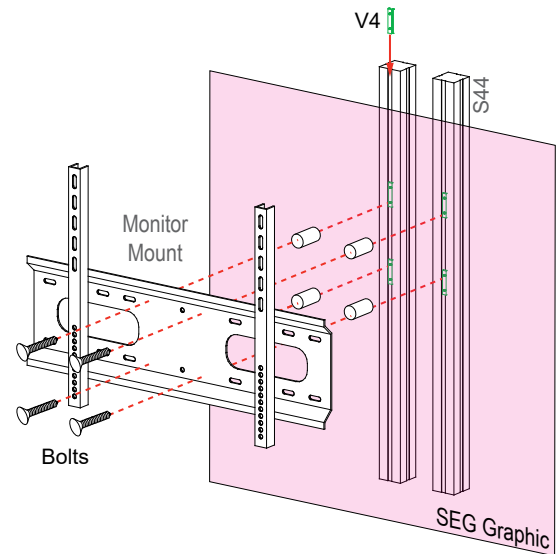
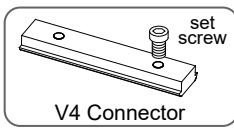

Attach Stand-off Barrels to V4 Connectors. Connect Monitor Mount to Standoff Barrels using Bolts.

*Note: Monitor mounts install through SEG graphic.*

Front Monitor Mount uses 2" standoff barrels

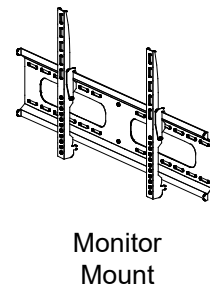

Back Monitor Mount uses 1" standoff barrels

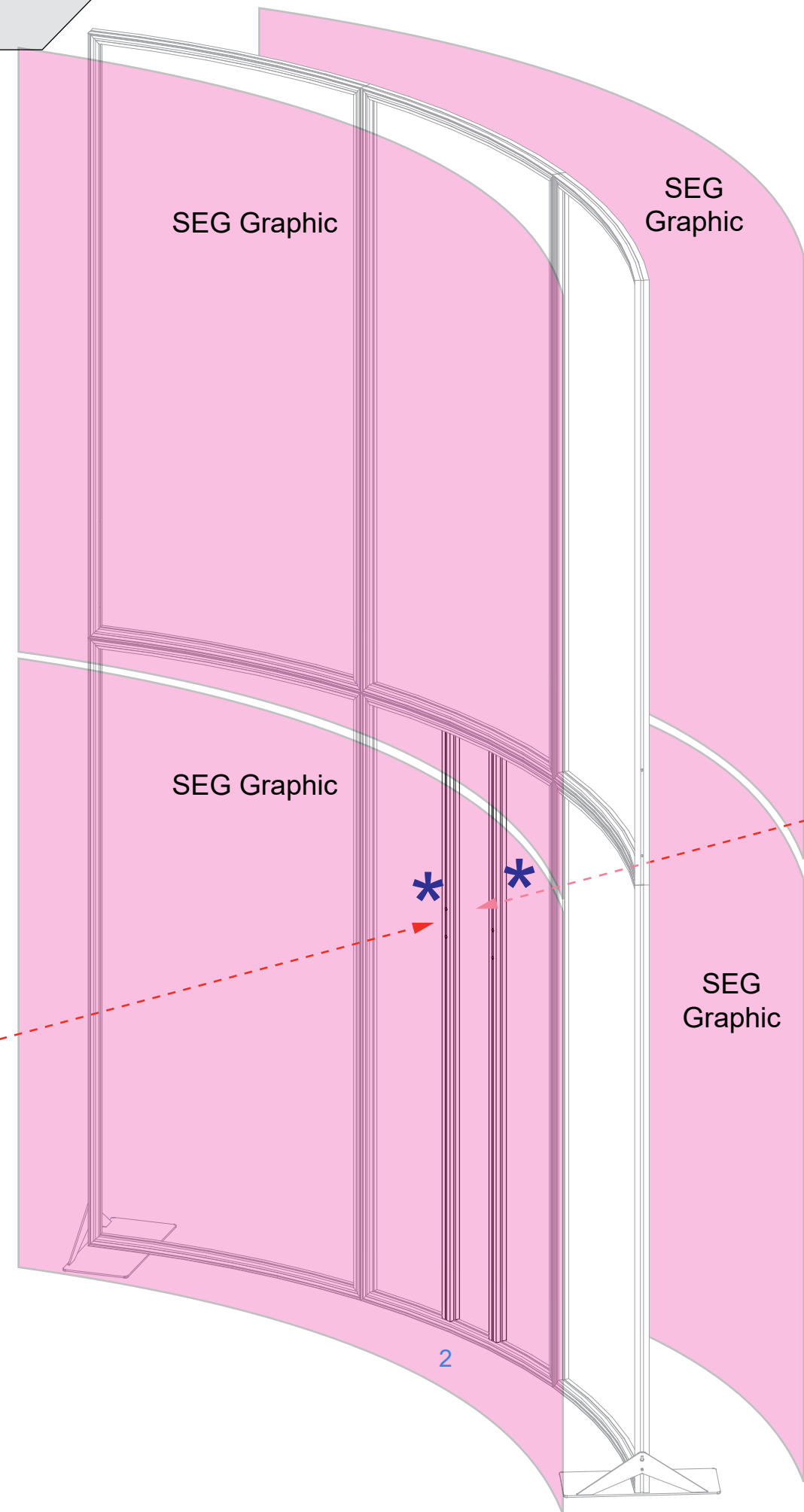
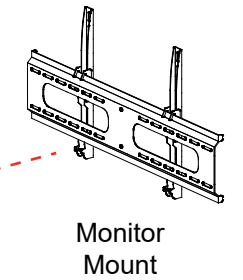



Item	Qty.	Description
9	2	38" h Q914 Vertical Extrusion
10	2	38" h Q914 Vertical Extrusion
11	2	38" h Q914 Vertical Extrusion
12	2	38" h Q914 Vertical Extrusion
13	2	22" w Z45 Horizontal Extrusion
14	2	22" w Z45 Horizontal Extrusion
15	2	7.313" w Z45 Horizontal Extrusion
16	2	7.313" w Z45 Horizontal Extrusion
17	2	7.313" w Z45 Horizontal Extrusion
18	2	7.313" w Z45 Horizontal Extrusion
19	2	22" w Z45 Horizontal Extrusion
20	2	22" w Z45 Horizontal Extrusion

Steps:

- 1) Assemble lower horizontals [13,15,17,19] between verticals [9,10,11,12].
- 2) Insert infill between verticals [9,10].
- 3) Attach upper horizontals [14,16,18,20], securing infills.
- 4) Attach Door between verticals [11,12]. See [Door Attachment](#) detail.
- 5) Affix Sintra covers to front of verticals [11,12], affix Sintra panels to sides of assembly as shown, using Velcro.
- 6) Affix Shelf Supports to inside of assembly; place internal shelf onto supports.
- 7) Attach Counter Top to assembly. See [Counter Top Attachment](#) detail.

Repeat steps for other Kiosk unit.

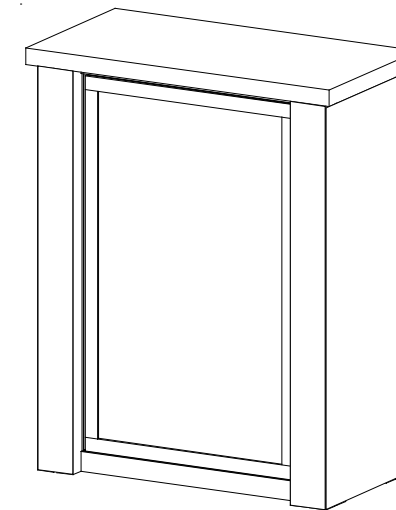

When partly assembled

Qty. 2

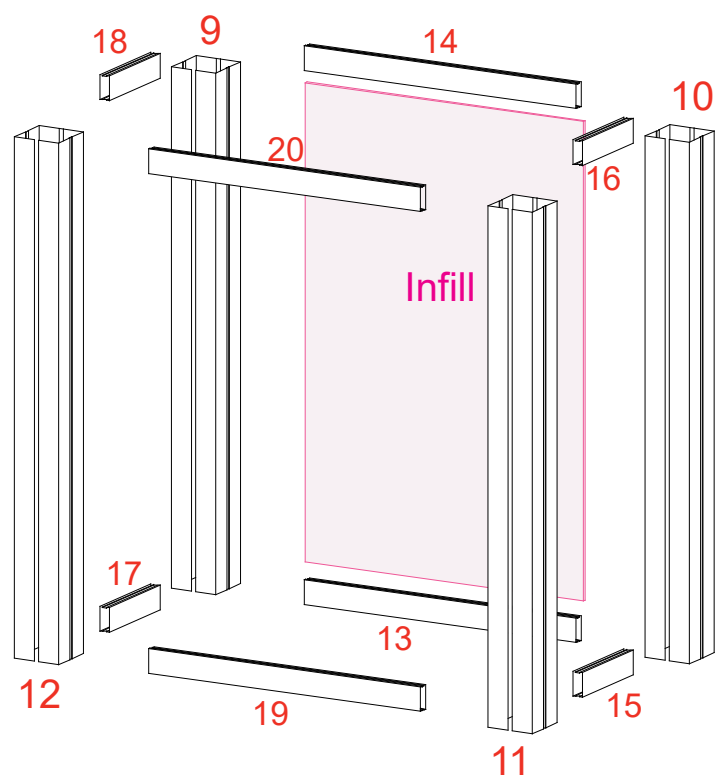

FRONT VIEW

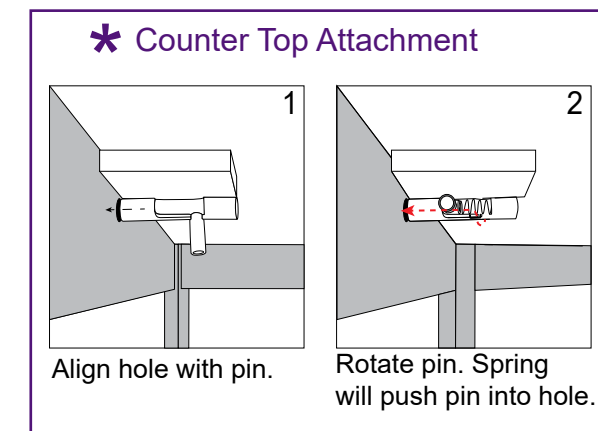
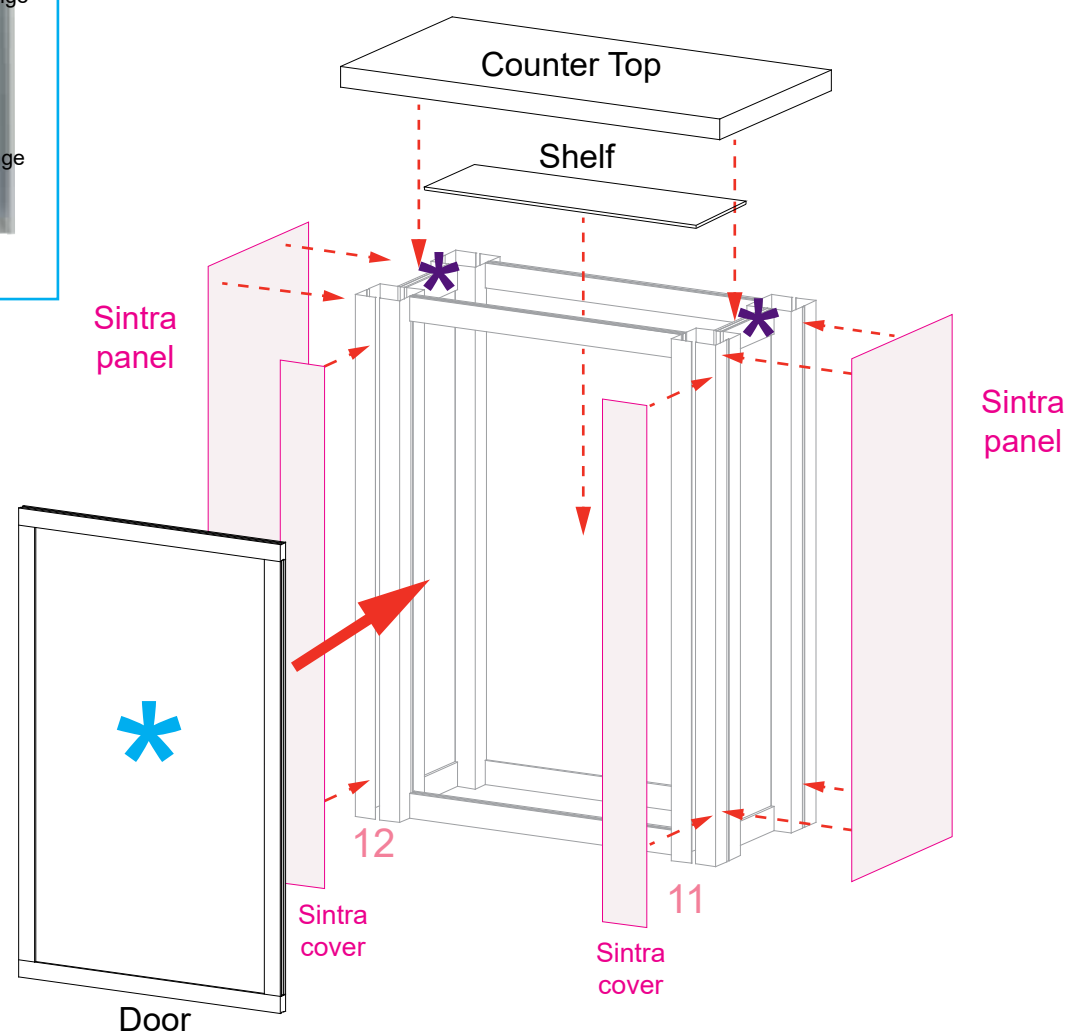
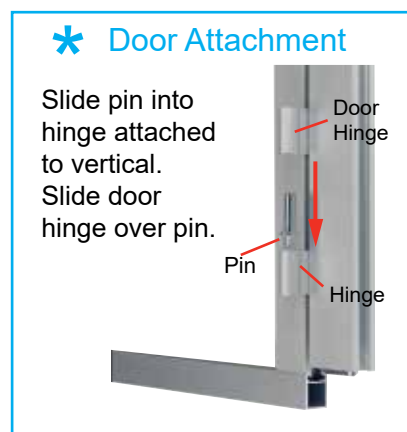

Item	Qty.	Description
4,5	1,1	96" h Q914 Vertical Extrusion
4A,5A	1,1	96" h Q914 Vertical Extrusion w/ insert top
6	2	22" w Q914 Horizontal Extrusion
7	2	22" w Q914 Horizontal Extrusion
8	2	22" w Q914 Horizontal Extrusion

Steps:

Note: Assemble extrusions on the ground.

- 1) Left Kiosk: Assemble horizontals [6,7,8] between verticals [4A,5].
- 2) Right Kiosk: Assemble horizontals [6,7,8] between verticals [4,5A].
- 3) Affix Sintra graphics to front of left & right assemblies as shown, using Velcro.

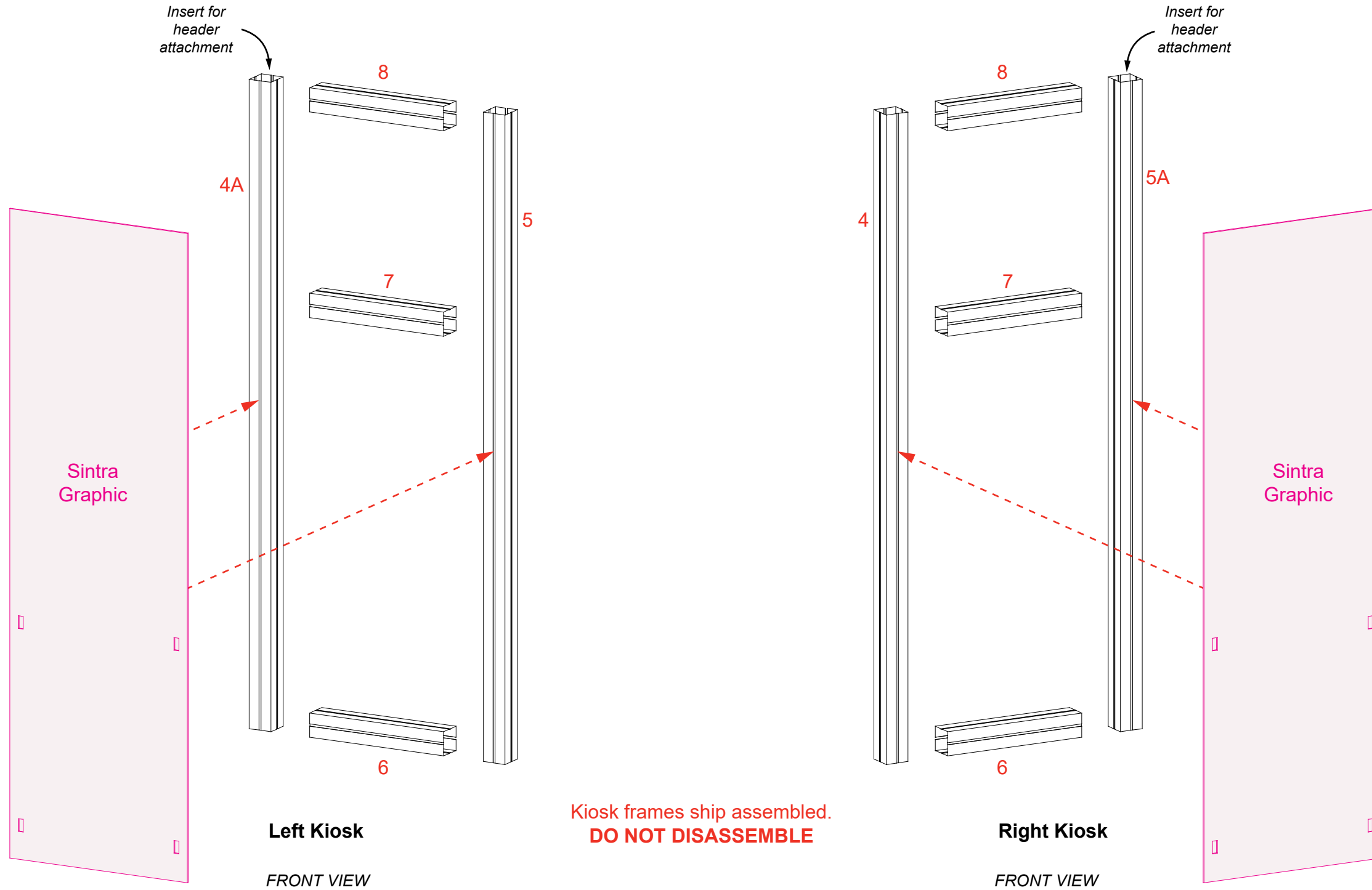

Item	Qty.	Description
21	2	3.5" w Z45 Horizontal Extrusion
22	2	3.5" w Z45 Horizontal Extrusion
23	2	3.5" w Z45 Horizontal Extrusion
24	2	3.5" w Z45 Horizontal Extrusion
--	1	Large Monitor Mount

- Steps:
- 1) Connect kiosk assembly to counter verticals [9,10], using horizontals [21,22,23,24] as shown.
  - 2) Install Monitor Mount to horizontal [7]. See [Monitor Mount Attachment](#) detail.
  - 3) Affix Sintra Graphic to back of assembly [4/5/6/7/8] using Velcro.

**Repeat steps for other Kiosk unit.**

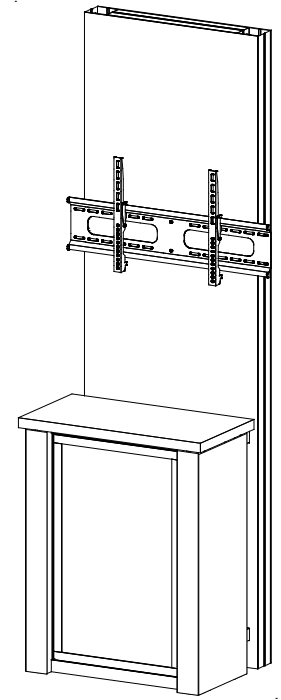
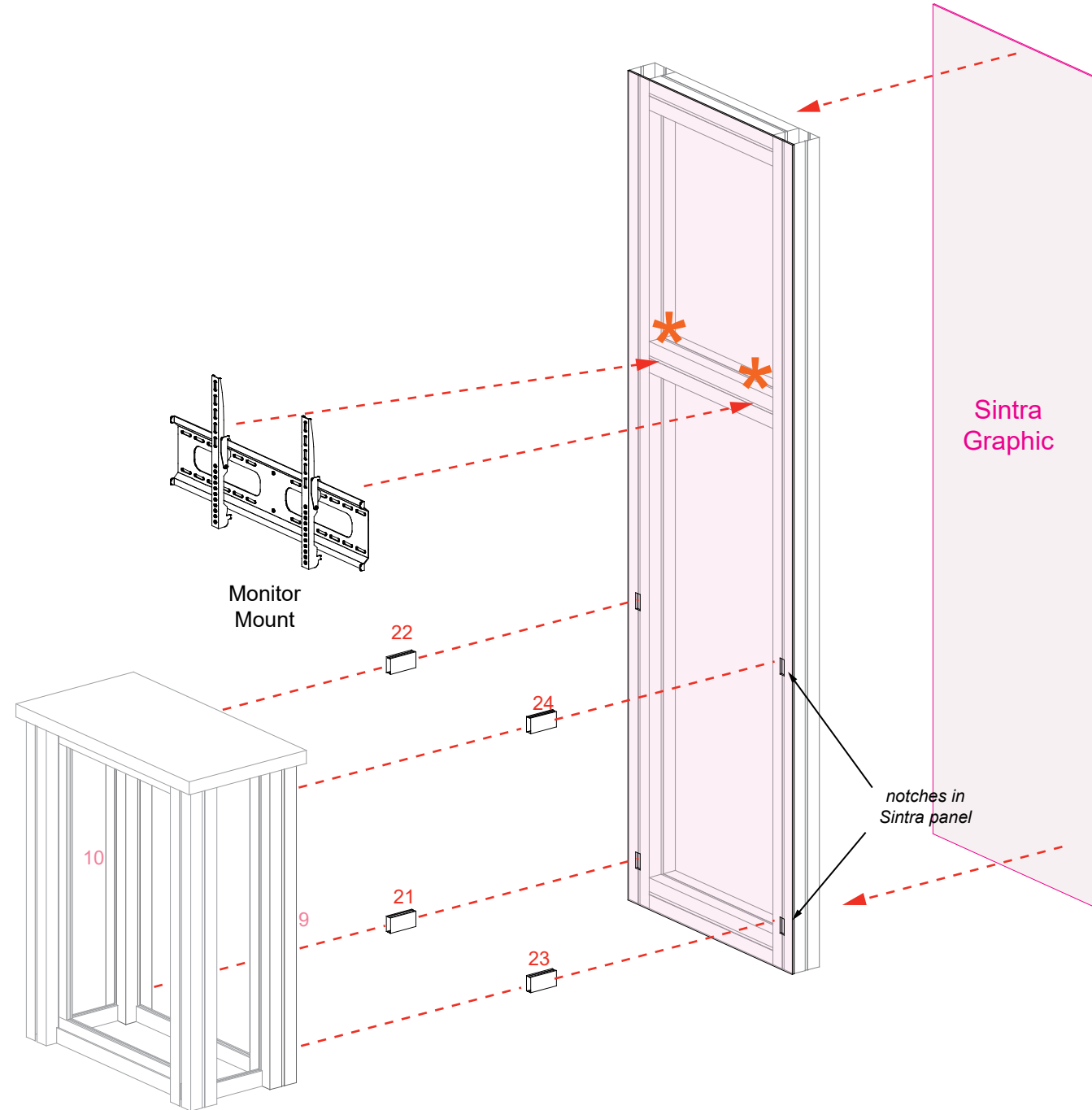

When assembled  
Qty. 2

**\* Monitor Mount Attachment**

Slide V4 connectors into horizontal channel of extrusions. Tighten set screws to secure.

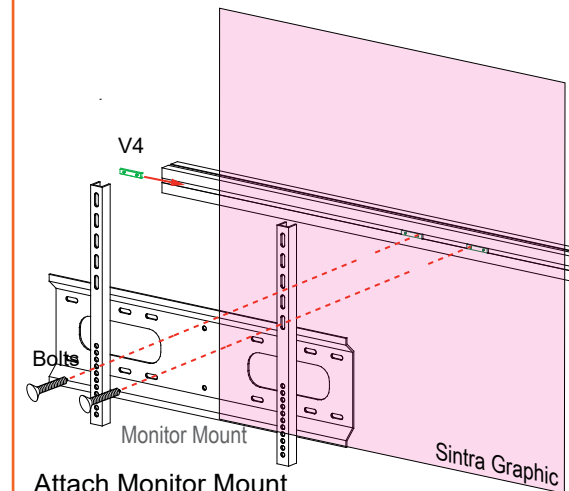
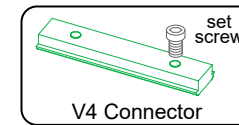

Attach Monitor Mount to V4 connectors using bolts.

*Note: Monitor mount installs over Sintra graphic.*

Item	Qty.	Description
2	1	94.208"w curved Z45 Horizontal Extrusion
3	1	94.208"w curved Z45 Horizontal Extrusion
4	1	17.417"h Z45 Vertical Extrusion
5	1	17.417"h Z45 Vertical Extrusion
6	1	17.417"h Z45 Vertical Extrusion
7	1	94.208"w curved Z45 Horizontal Extrusion
8	1	94.208"w curved Z45 Horizontal Extrusion
9	1	17.417"h Z45 Vertical Extrusion
10	1	17.417"h Z45 Vertical Extrusion
11	1	17.417"h Z45 Vertical Extrusion

Steps:

- 1) Assemble verticals [4,5,6] between horizontals [2,3],
- 2) Connect vertical [6] to panel [1] using **Bolt & Wing Nut Connection**.
- 3) Attach horizontal [2] to top of left Kiosk vertical [4A], using **Bolt**.
- 4) Assemble verticals [9,10,11] between horizontals [7,8],
- 5) Connect vertical [11] to panel [3] using **Bolt & Wing Nut Connection**.
- 6) Attach horizontal [7] to top of right Kiosk vertical [5A], using **Bolt**.
- 7) Affix graphics to front & back of assembled headers, using Velcro.

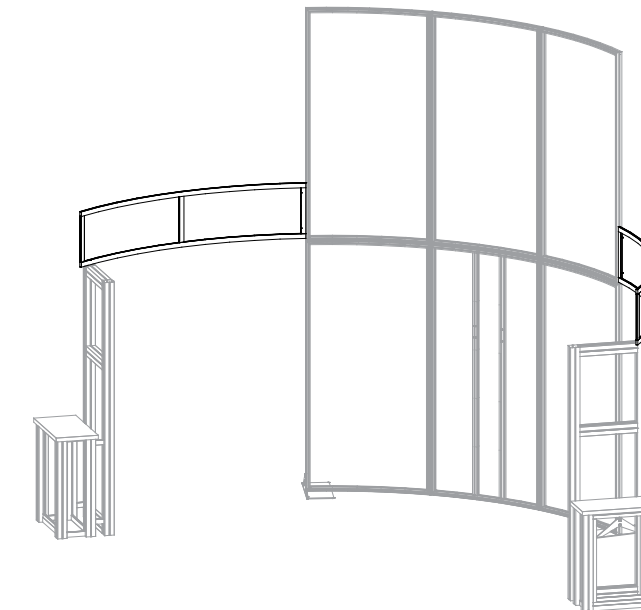

Section Being Assembled is Highlighted in BLACK

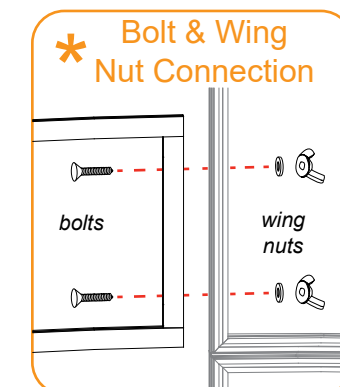
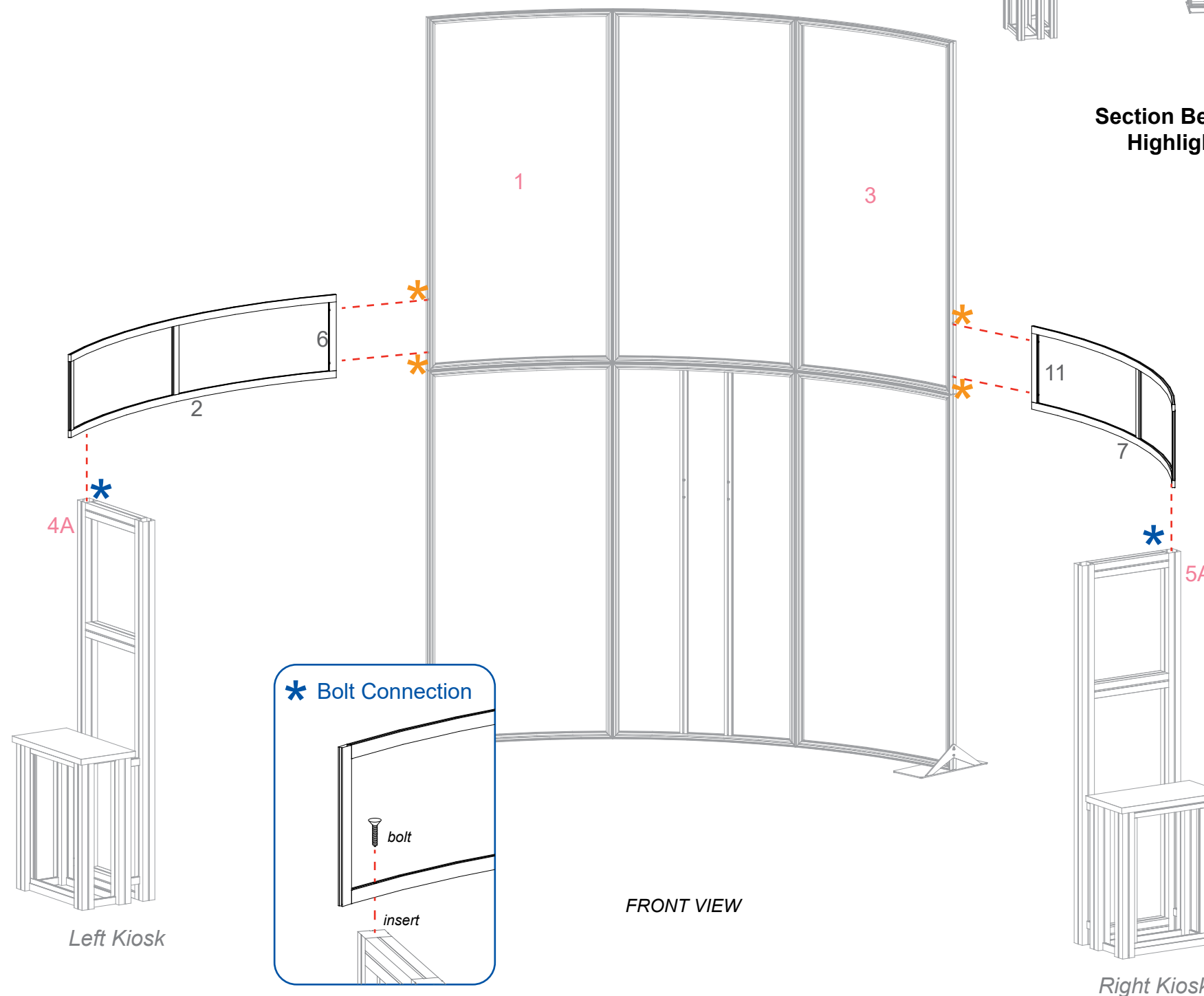
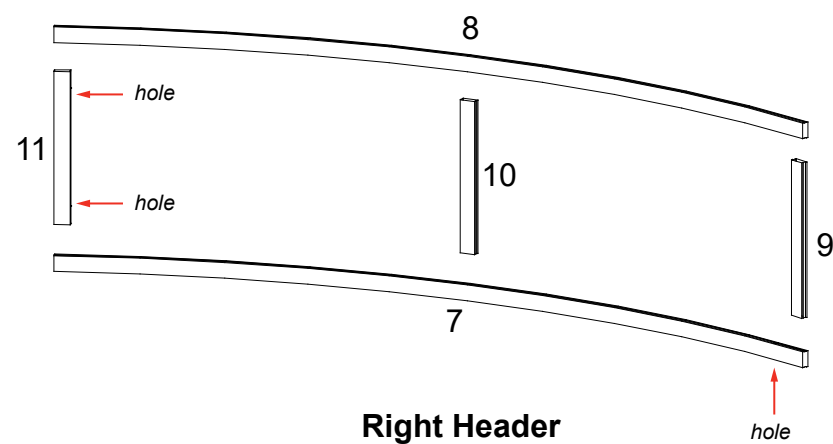
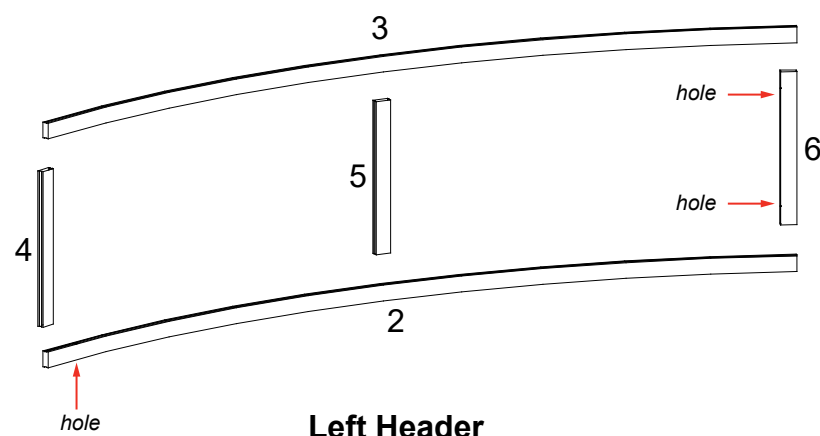

Item	Qty.	Description
1	1	38" h Q914 Vertical Extrusion
2	1	38" h Q914 Vertical Extrusion
3	1	38" h Q914 Vertical Extrusion
4	1	38" h Q914 Vertical Extrusion
5	1	38" h Q914 Vertical Extrusion
6	1	38" h Q914 Vertical Extrusion
7	1	32.155" w Z45 Horizontal Extrusion
8	1	32.155" w Z45 Horizontal Extrusion
9	1	32.155" w Z45 Horizontal Extrusion
10	1	32.155" w Z45 Horizontal Extrusion
11	1	15" w Z45 Horizontal Extrusion
12	1	15" w Z45 Horizontal Extrusion
13	1	32.155" w Z45 Horizontal Extrusion
14	1	32.155" w Z45 Horizontal Extrusion
15	1	32.155" w Z45 Horizontal Extrusion
16	1	32.155" w Z45 Horizontal Extrusion
17	1	15" w Z45 Horizontal Extrusion
18	1	15" w Z45 Horizontal Extrusion
19	1	15" w Z45 Horizontal Extrusion
20	1	15" w Z45 Horizontal Extrusion

Steps:

- 1) Assemble lower horizontals [7,9,11,13,15,17] between verticals [1,2,3,4,5,6].
- 2) Insert infills between verticals [1,2] & [2,3].
- 3) Attach upper horizontals [8,10,12,14,16,18], securing infills.
- 4) Attach Doors between verticals [1,6], [3,4].  
See [Door Attachment](#) detail.
- 5) Affix front graphic to verticals [4,5,6], using Velcro.
- 6) Affix Sintra covers to sides of verticals [1,3,4,6], using Velcro.
- 7) Affix Shelf Supports to inside of assembly; place internal shelves onto supports.
- 8) Attach Counter Top to assembly. See [Counter Top Attachment](#) detail.

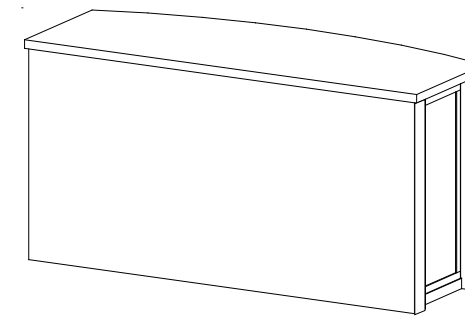

FRONT VIEW

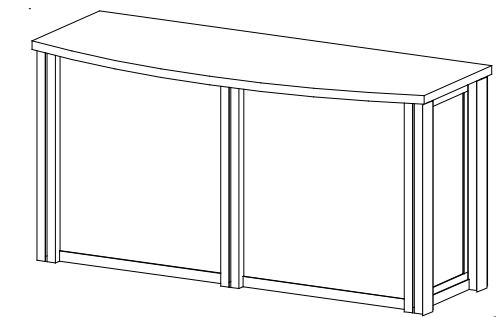

BACK VIEW

Completed Counter Assembly

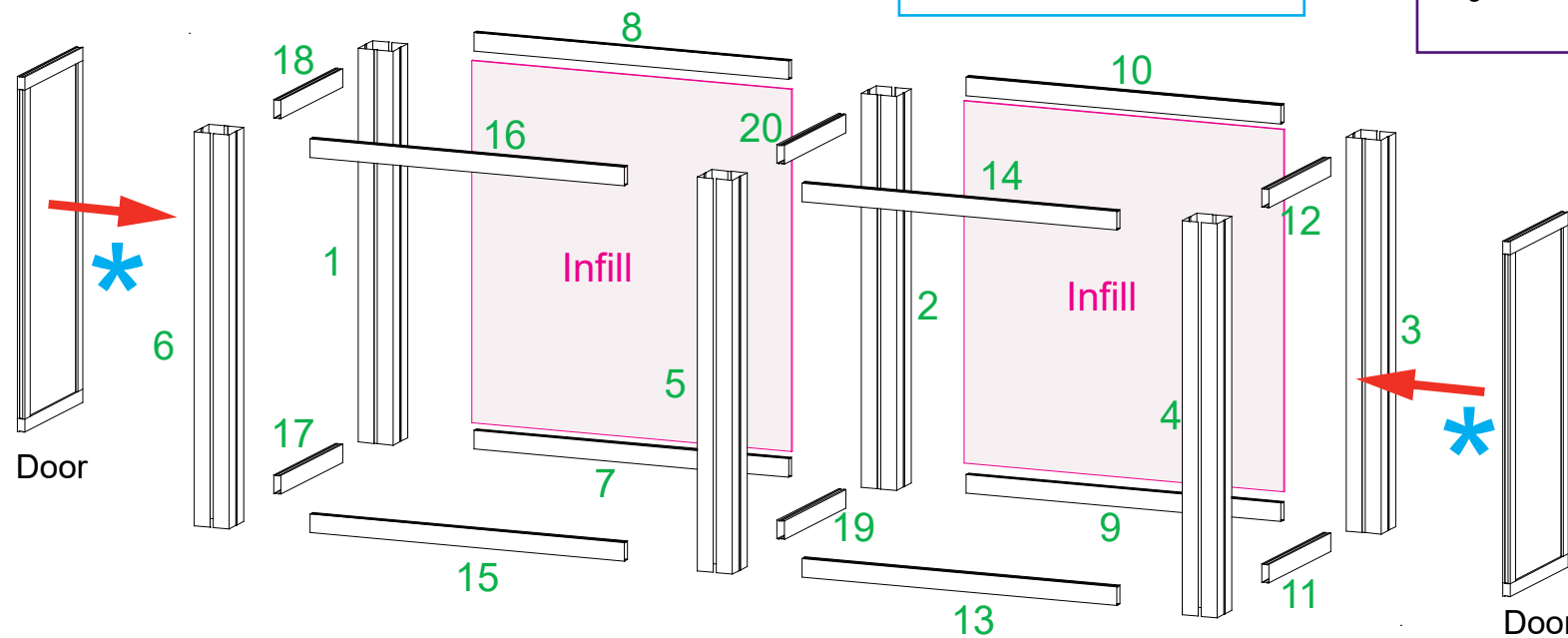
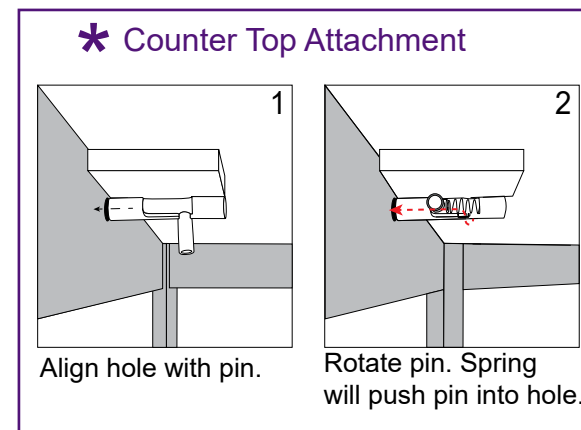
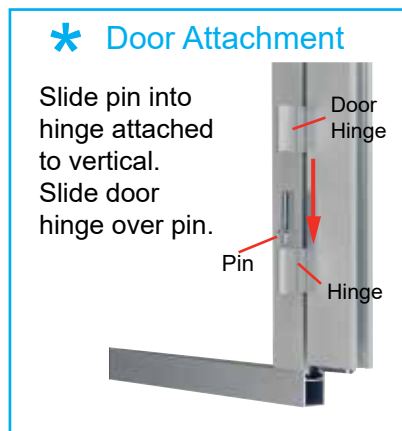

FRONT VIEW

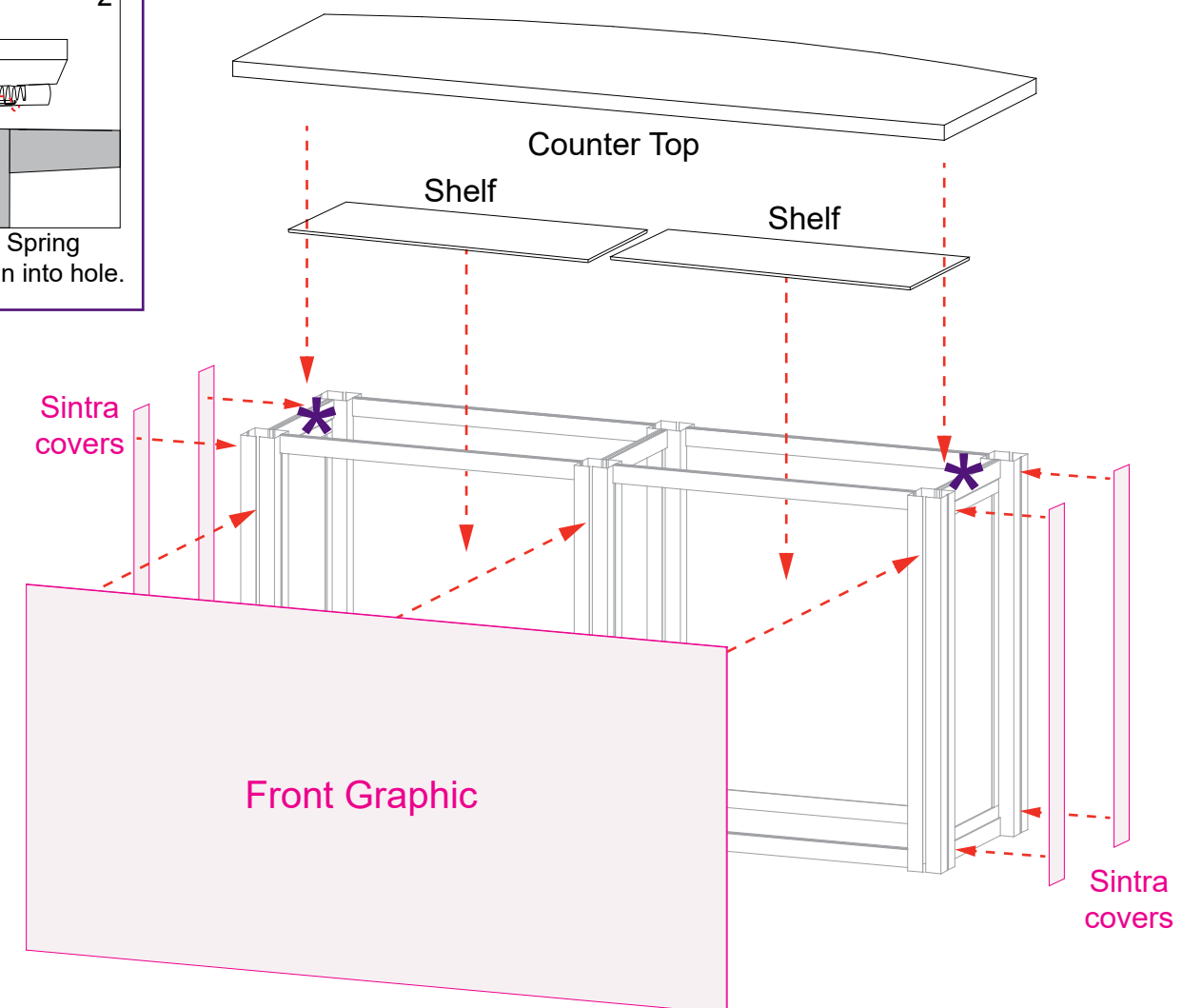

Item	Qty.	Description
4	1	47.123"w x 95"h Curved Gravitee panel w/ S44
12	2	Corner Base Plate
--	1	Large Monitor Mount
--	4	1" Standoff Barrel

Steps:

- 1) Attach Base Plates [12] to panel [4]. See [Base Plate Attachment](#) detail.
- 2) Apply SEG graphic to front of panel [4]. Refer to the [SEG Installation general information page](#).
- 3) Attach Monitor Mount to front of panel [4]. See [Monitor Mount Attachment](#) detail.
- 4) Apply SEG graphic to back of panel [4].

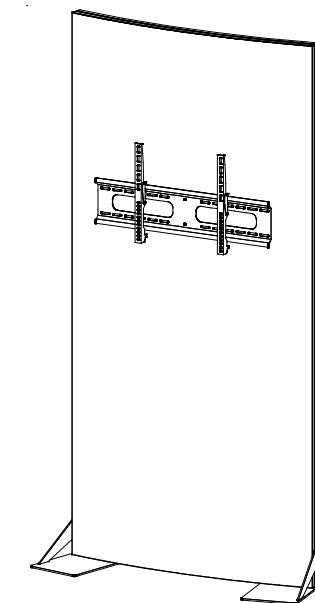
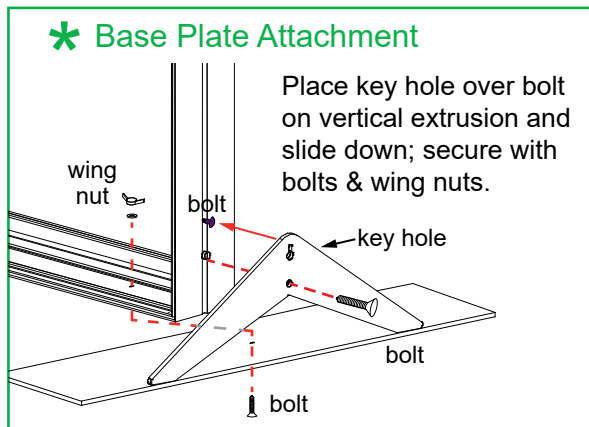

When assembled

Keep internal extrusions attached to Gravitee panel.  
DO NOT REMOVE.

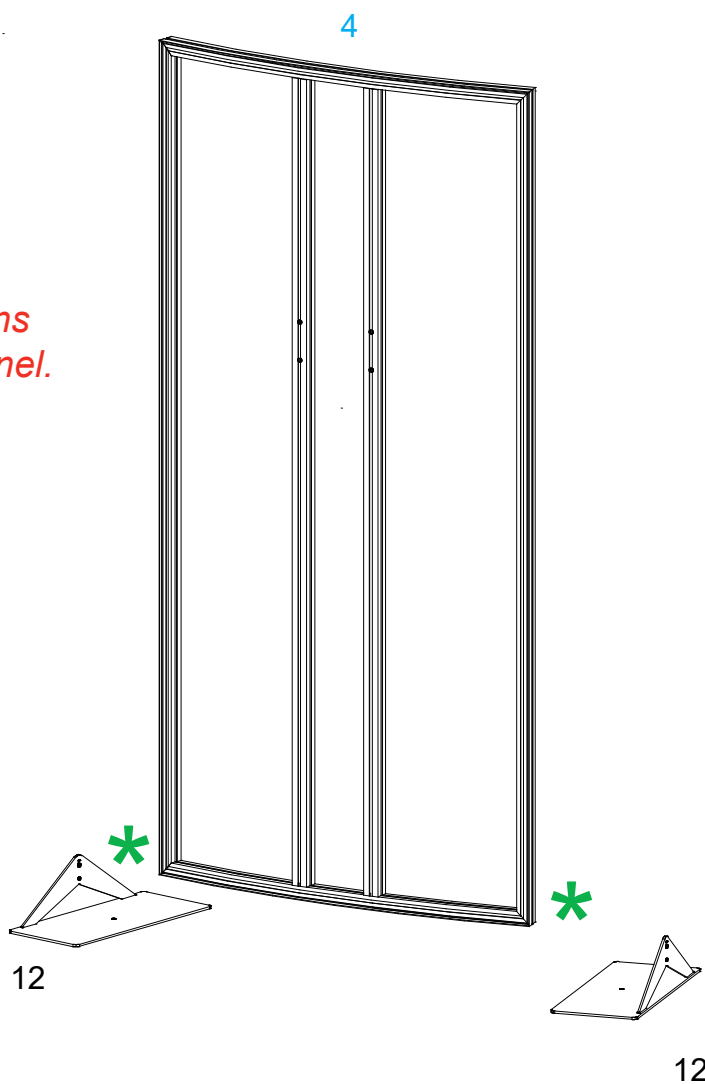

Monitor Mount uses 1" standoff barrels

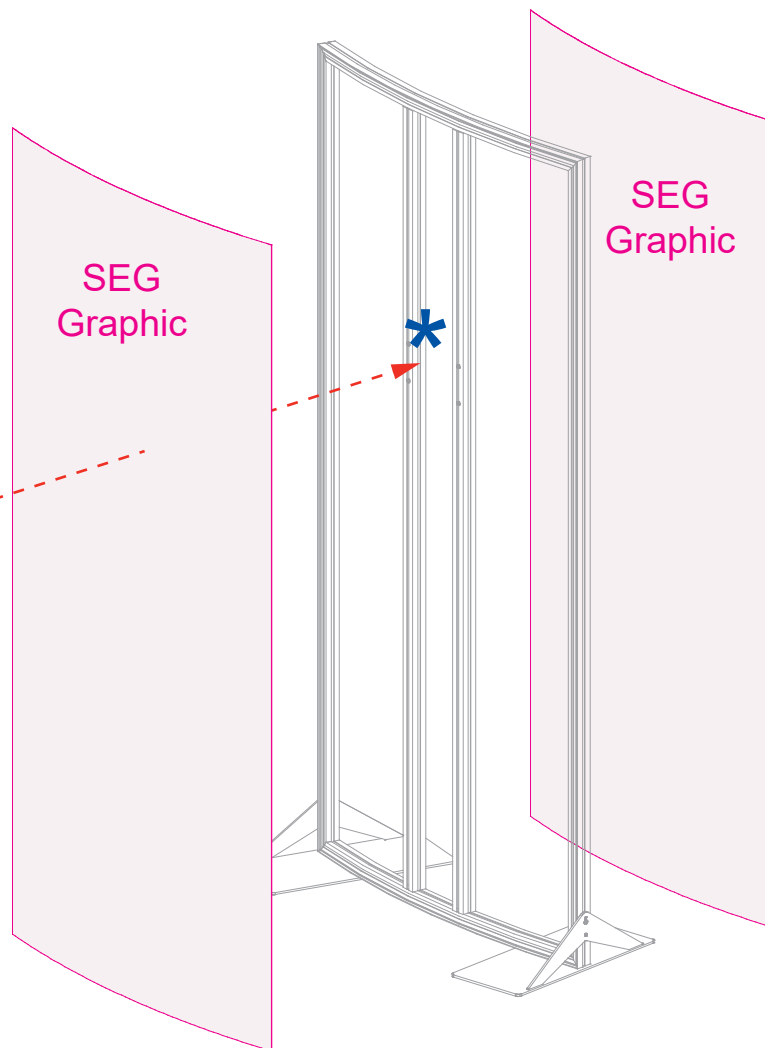
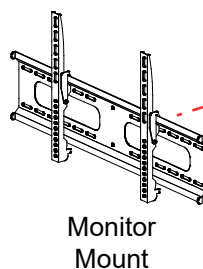

**\* Monitor Mount Attachment**

Slide V4 connectors into vertical channel of extrusions & tighten set screws to secure in place.

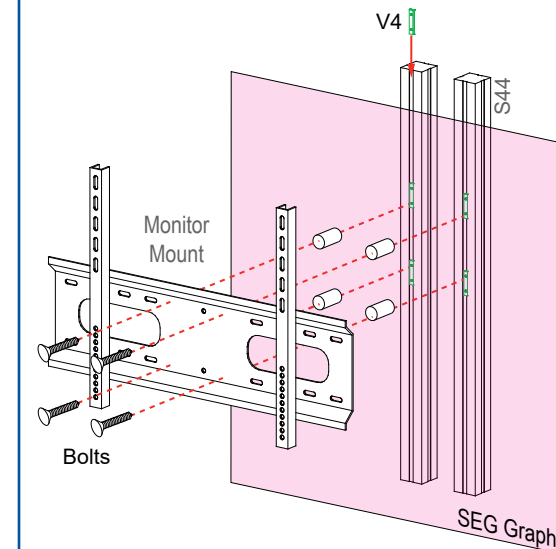
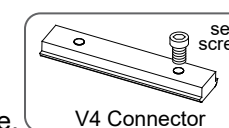

Attach Stand-off Barrels to V4 Connectors. Connect Monitor Mount to Standoff Barrels using Bolts.

*Note: Monitor mounts install through SEG graphic.*

Item	Qty.	Description
5	1	38" h GS220 Vertical Extrusion
6	1	38" h GS220 Vertical Extrusion
7	1	38" h GS210 Vertical Extrusion
8	1	38" h GS210 Vertical Extrusion
9	1	45.831" w Z45 Horizontal Extrusion
10	1	45.831" w Z45 Horizontal Extrusion
11	1	34.417" h Z45 Vertical Extrusion
12	1	12.5" w Z45 Horizontal Extrusion
13	1	12.5" w Z45 Horizontal Extrusion
14	1	12.5" w Z45 Horizontal Extrusion
15	1	12.5" w Z45 Horizontal Extrusion
16	1	50.523" w curved Z45 Horizontal Extrusion
17	1	50.523" w curved Z45 Horizontal Extrusion

Steps:

- 1) Assemble lower horizontals [9,12,14,16] between verticals [5,6,7,8].
- 2) Insert infills between verticals [5,8], [6,7], [7,8].
- 3) Attach upper horizontals [10,13,15,17], securing infills.
- 4) Connect vertical [11] between horizontals [9,10].
- 5) Attach Doors between verticals [5,11], [6,11].  
See [Door Attachment](#) detail.
- 6) Affix Shelf Supports to inside of assembly; place internal shelf onto supports.
- 7) Connect plex counter to countertop using standoff barrels & caps.  
See [Plex Counter Attachment](#) detail.
- 8) Attach Counter Top to assembly. See [Counter Top Attachment](#) detail.

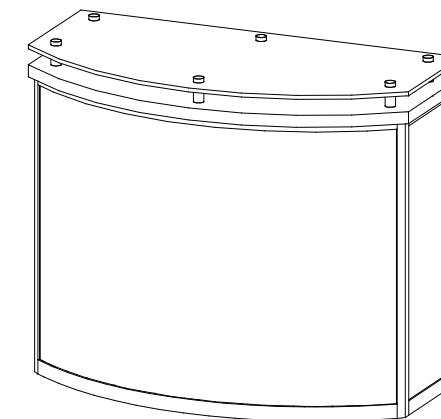

Completed Counter Assembly

