

Item	Qty.	Description
1	1	37.5" S39 Vertical Extrusion
2	1	37.5" S39 Vertical Extrusion
3	1	37.5" S39 Vertical Extrusion
4	1	37.5" S39 Vertical Extrusion
5,5A	2,2	10.5" Z45 Horizontal Extrusion
6,6A	2,2	18" Z45 Horizontal Extrusion
7,7A	1,1	22.811" Z45 Horizontal Extrusion
8,8A	1,1	42"h S44 Vertical Extrusion
9	2	10" Z41 Horizontal Extrusion w/ Caps
10	1	20" Z41 Horizontal Extrusion w/ Cap
11	1	22" Z41 Horizontal Extrusion w/ Cap

**Steps:**

- 1) Attach horizontal extrusions [5] to the base of vertical extrusion [8].
- 2) Attach vertical extrusions [1] & [2] to horizontal extrusions [5].
- 3) Insert **infill** panels, then secure with horizontal extrusions [5A].
- 4) Attach horizontal extrusions [6] to the base of vertical extrusions [1] & [2].
- 5) Attach vertical extrusions [3] & [4] to horizontal extrusions [6].
- 6) Insert **infill** panels, then secure with horizontal extrusions [6A].
- 7) Connect horizontal extrusion [7] & [7A] between vertical extrusions [3] & [4].
- 8) Connect assembled door to vertical [3]. See **Door Attachment** detail.
- 9) Affix Shelf Supports to inside of counter assembly, using Velcro; place internal **Shelf** onto shelf supports.
- 10) Lock counter top to horizontals [6A].
- 11) Attach vertical extrusion [8A] to vertical extrusion [8]. See **Vertical Connector** detail.
- 12) Connect horizontal extrusions [9] to base of vertical extrusion [1A].
- 13) Insert **wing panels**, then secure with horizontal extrusions [10] & [11].
- 14) Connect monitor mount to vertical extrusion [8A]. See **Monitor Mount** detail.

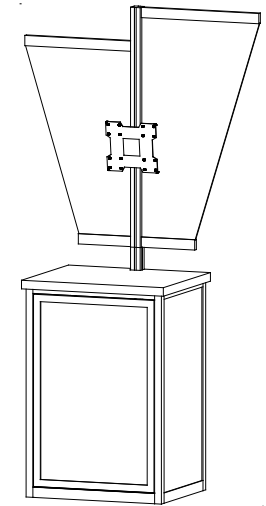
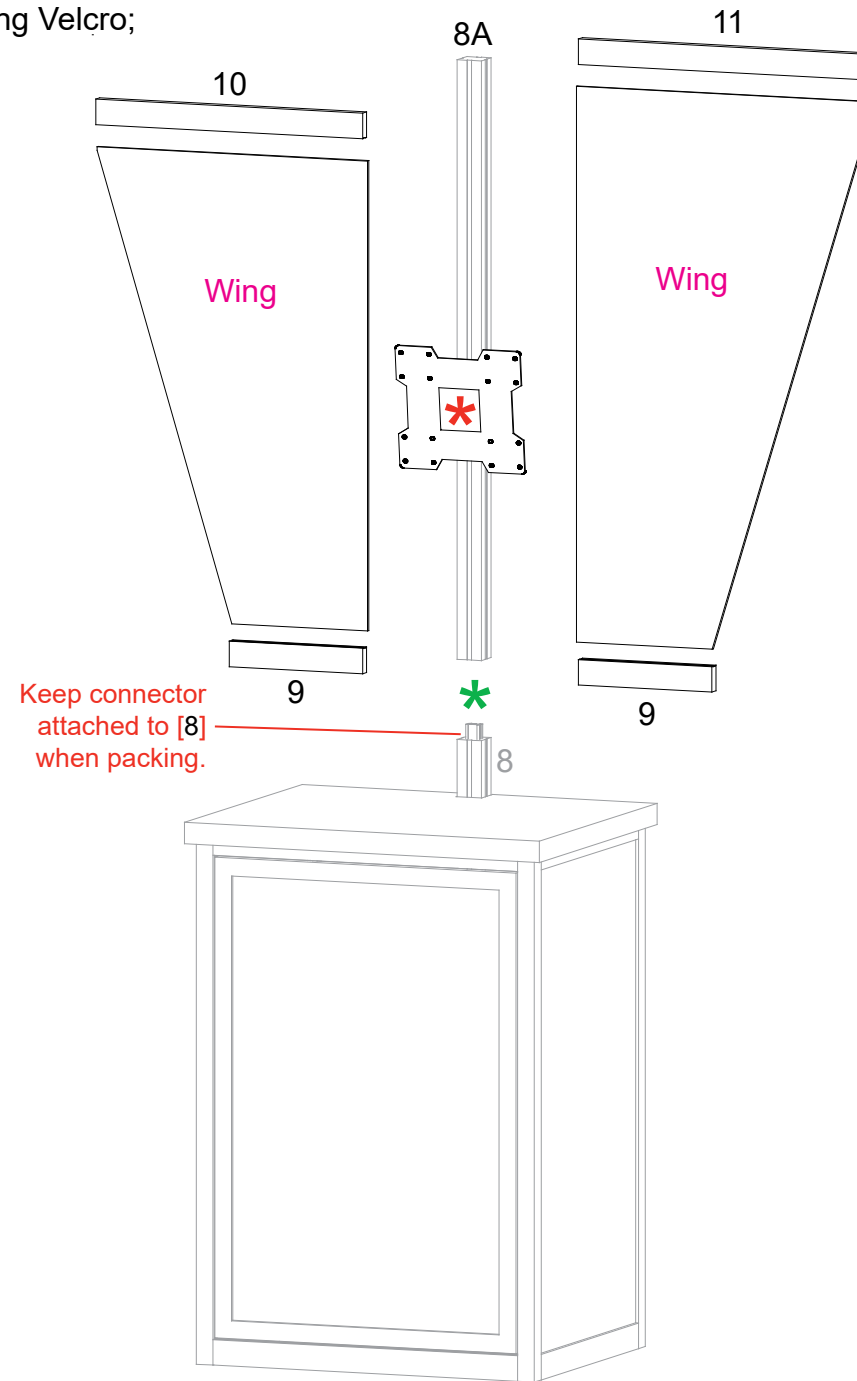
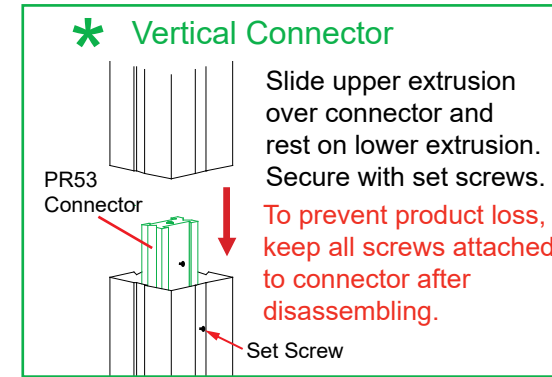
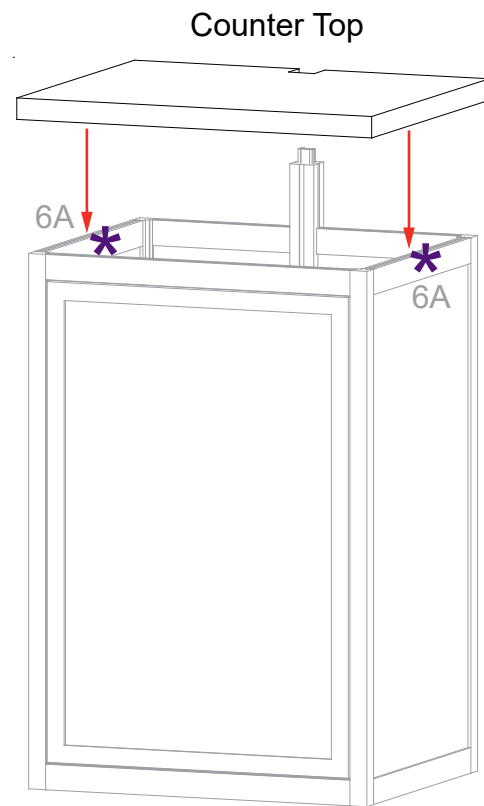
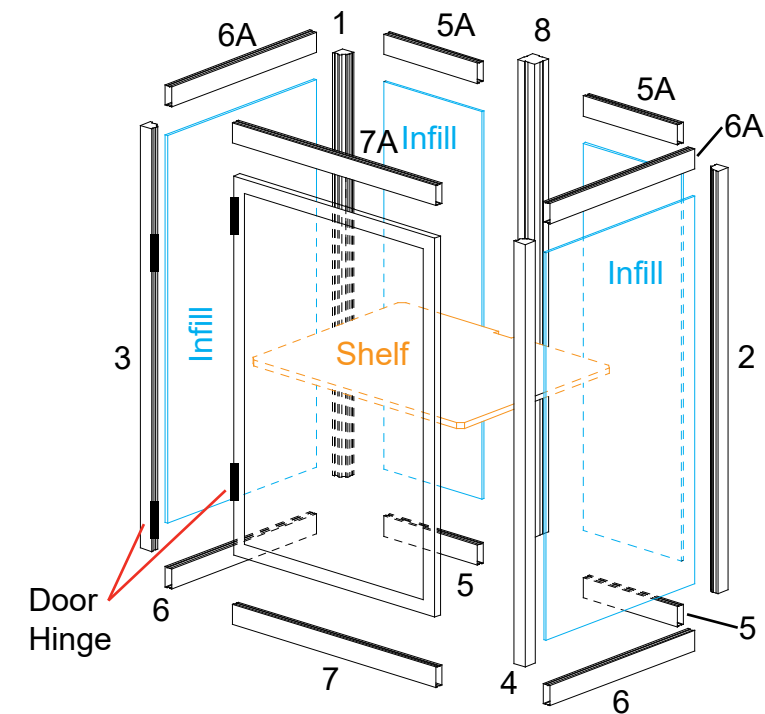
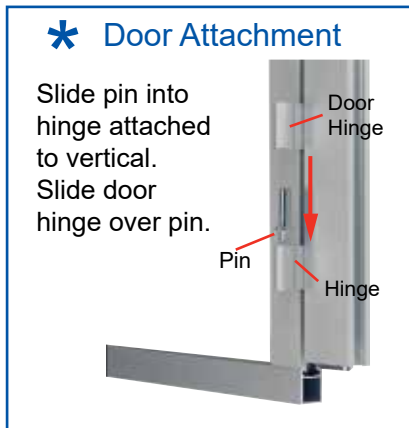

Completed Assembly

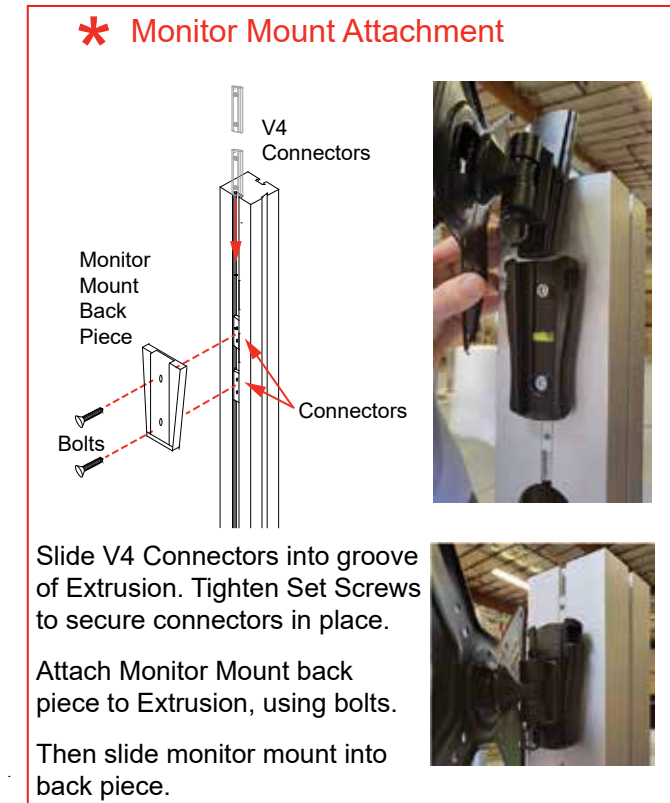
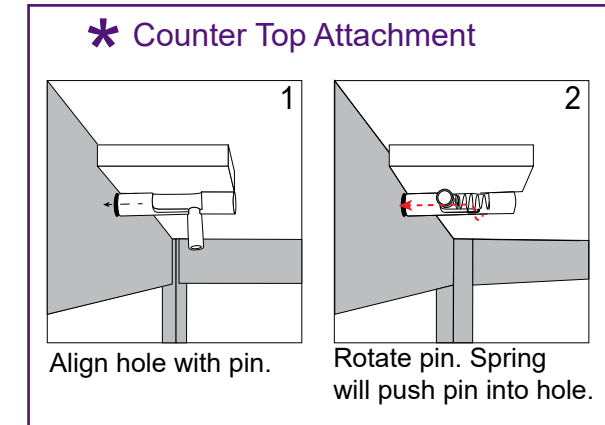

## General Setup Instructions

- Read entire setup instruction manual prior to unpacking parts and pieces.
- The setup instructions are created specifically for this configuration.
- Setup instructions are laid out sequentially in steps, including exploded views with detailed explanation for assembly.

## Cleaning & Packing

- For Cleaning Metal, Plex, & Laminate Parts: Use a **MILD NON-ABRASIVE** cleanser and soft cloth/paper towel to clean all surfaces.
- Keep exhibit components away from heat and prolonged sun exposure. **Heat and UV exposure will warp and fade components.**
- Retain all provided Packing Materials. All provided packing materials are for ease of repacking & component protection.

## Disassembly

- For loss prevention, tighten all set screws and locks during disassembly.

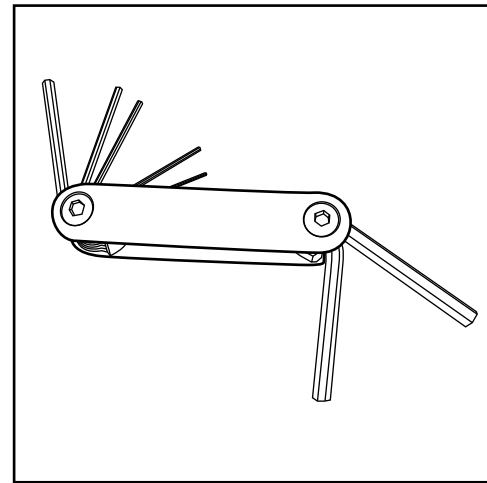

Hex Tool - Essential for Assembly

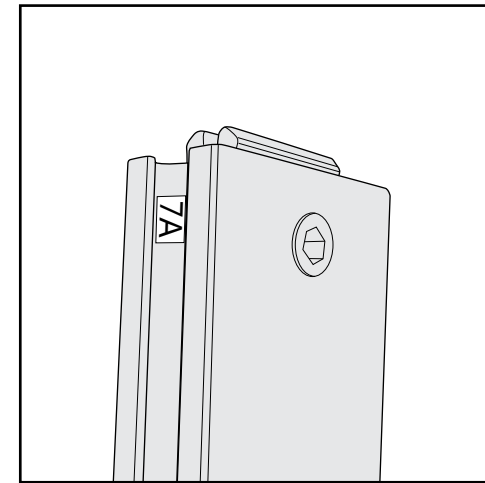

Part Identification - Numbering

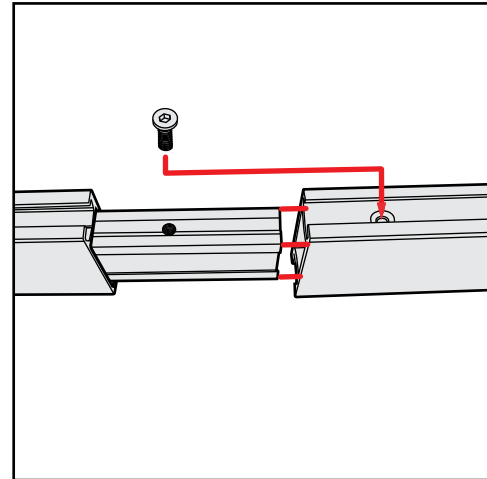

Spline Connection

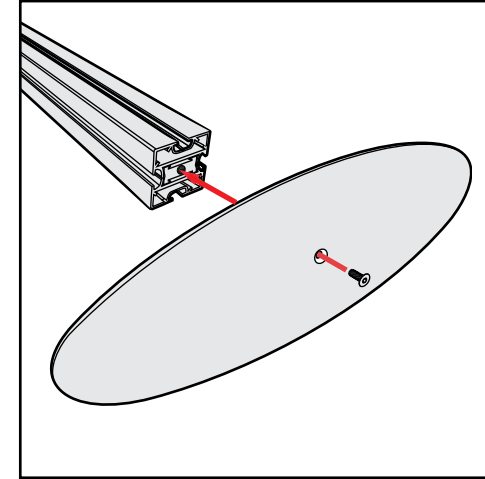

Base Plate & Extrusion Connection

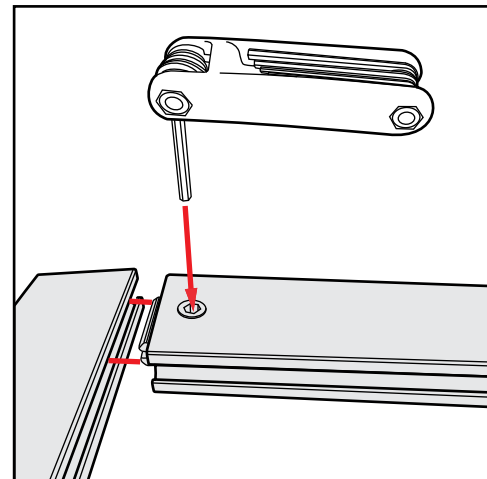

Extrusion & Lock Connection

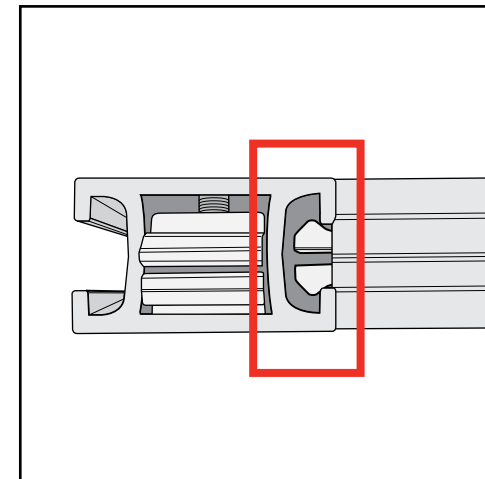

Engaged Lock



**WARNING**

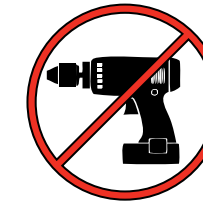

DO NOT USE POWER TOOLS

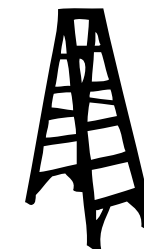

LADDERS OR LIFTS  
MAY BE REQUIRED



ALL CONNECTIONS MUST  
BE TIGHTLY SECURED